

User's Guide

TRENDNET[®]



**5 dBi WiFi 6 AX1800 Outdoor PoE+
Omni-Directional Access Point**

TEW-941 APBO

Contents

Product Overview	1
Package Contents	1
Features	1
Product Hardware Features.....	3
Primary Product Application	5
Application Diagram	5
Minimum Installation Requirements	6
Wireless Installation Tips.....	6
Quick Reference	7
TEW-941APBO	7
TEW-941APBO Basic Installation and Configuration (Basic Access Point Setup)	8
Hardware Setup.....	8
Basic Access Point Configuration.....	8
Hardware and Mounting Installation	12
Waterproof Kit Installation.....	12
Pole Mount Installation	13
Application Modes	14
Access Point (AP)	14
Client Bridge	14
Repeater	15
.....	15
Accessing your access point management page	16
Access your access point management page	16
Overview	17

Device Status	17
2.4GHz Wireless/5GHz Wireless Status.....	19
System Log.....	20
System Log.....	20
System.....	21
IP Settings	21
IPv6 Settings	22
Cloud Settings (Hive)	22
Spanning Tree Protocol (STP) Settings	23
Band Steer	23
Airtime Fairness.....	24
Management VLAN.....	24
Time and Date Settings.....	24
Schedule	25
LED Control.....	26
LLDP	26
UPnP	26
Bonjour	27
Gateway Monitor	27
Wireless 2.4GHz / 5GHz Network	27
Wireless Network	27
Bandwidth Control	29
Wireless RSSI Scanner.....	29
Wireless MAC Filter	30
Wireless Advanced Settings.....	30
WPS	31
Management	32

System Management..... 32
Administration..... 32
Timeout Settings..... 32
SNMP Settings 33
Settings Management..... 34
Settings Management..... 34
SSH..... 35

System Log..... 35
Diagnostics..... 35
Technical Specifications 37
Appendix 41

Product Overview

TEW-941APBO Overview



Package Contents

TEW-941APBO package includes:

- TEW-941APBO
- 2 x Detachable 2.4GHz 5 dBi antennas
- 2 x Detachable 5GHz 5 dBi antennas
- IP67 weather rated cable gland
- Mounting hardware
- Quick Installation Guide

If any package contents are missing or damaged, please contact the retail store, online retailer, or reseller/distributor from which the product was purchased.

Features

TRENDnet's 5 dBi WiFi 6 AX1800 Outdoor PoE+ Omni-Directional Access Point, model TEW-941APBO, is designed for point-to-point and point-to-multi-point WiFi bridging applications. This WiFi 6 outdoor access point can be powered with an IEEE 802.3at PoE+ switch or injector. The WiFi 6 outdoor omnidirectional AP supports point-to-point and point-to-multi-point scenarios with Access Point, Client Bridge, and Repeater modes. The IP67 rated housing on this WiFi 6 outdoor access point is designed for outdoor environments, and conveniently includes wall and pole mounting hardware.

Easily manage and configure TRENDnet's 5 dBi WiFi 6 AX1800 Outdoor PoE+ Omni-Directional Access Point remotely with TRENDnet Hive. TRENDnet Hive is a remote network cloud manager that reduces management time and cost. No additional hardware, server, or personal cloud is required with this WiFi 6 access point and TRENDnet's reliable cloud service.



Concurrent Dual Band

AX1800: Concurrent 1201Mbps (5GHz) + 573Mbps (2.4GHz) bands

Wireless Modes

Supports Access Point, Client Bridge, and Repeater modes

Outdoor Ready

The outdoor wireless 6 access point features a durable enclosure with an IP67 weather rating

Omni-Directional Antenna

2 x 5 dBi 2.4GHz antennas, 2 x 5 dBi 5GHz antennas

PoE+ Powered

Supports 2.5G 802.3at PoE+ power input

Encrypted Wireless

Support for wireless encryption of up to WPA3

Multiple SSID

Create up to eight dual band SSIDs with band steering capabilities

Mounting Hardware

Pole and wall mount hardware are conveniently included with this WiFi 6 outdoor access point

Hive Enabled (Optional)

Remotely monitor, manage, configure, and diagnose this WiFi 6 access point via TRENDnet's reliable cloud service (Additional fee applies)

*Effective wireless coverage may vary depending on the wireless device's output power, antenna gain, antenna alignment, receiving sensitivity, and radio interference. Additionally environmental factors such as weather conditions, physical obstacles, and other considerations may affect performance. For optimal results, we recommended consulting a professional installer for site survey, safety precautions, and proper installation.

**Maximum wireless signal rates are referenced from IEEE 802.11 theoretical specifications. Actual data throughput and coverage will vary depending on interference, network traffic, building materials and other conditions. For maximum performance of up to 867Mbps use with an 867Mbps 802.11ac wireless adapter. For maximum performance of up to 300Mbps, use with a 300Mbps 802.11n wireless adapter. For maximum performance of up to 1201Mbps use with a 1201Mbps 802.11ax 5GHz wireless adapter. For maximum performance of up to

573Mbps use with a 573Mbps 802.11ax 2.4GHz wireless adapter. Multi-User MIMO (MU-MIMO) requires the use of multiple MU-MIMO enabled wireless adapters.

Product Hardware Features

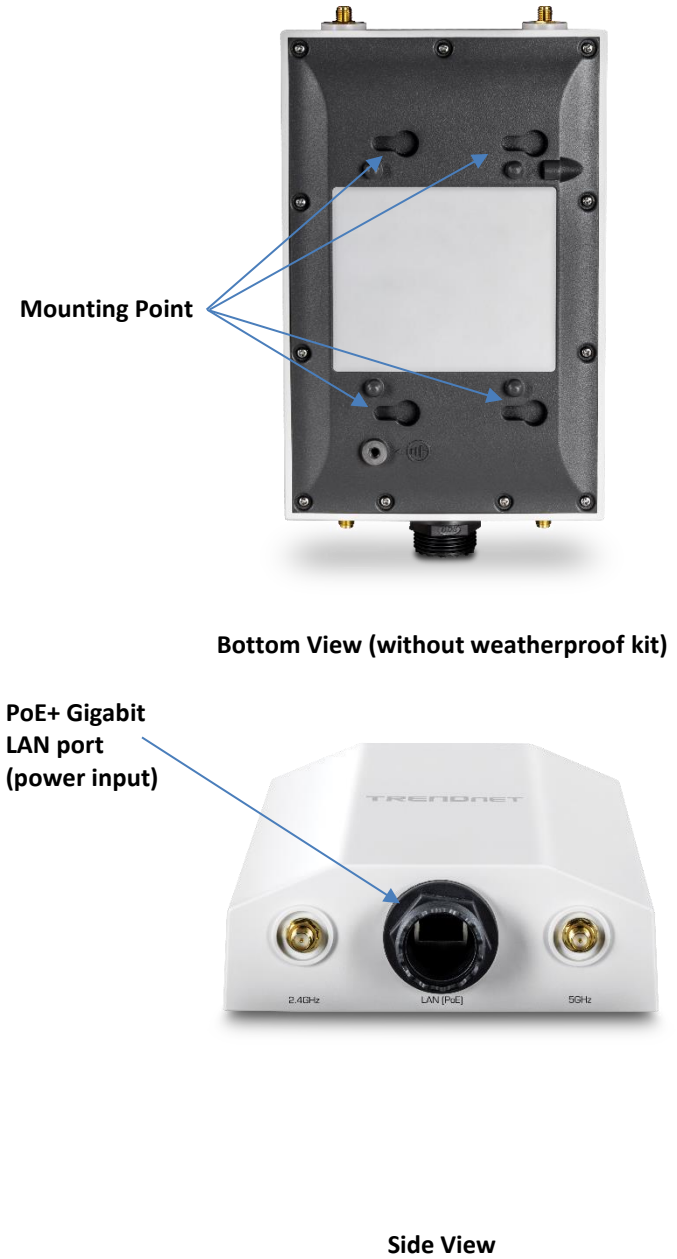
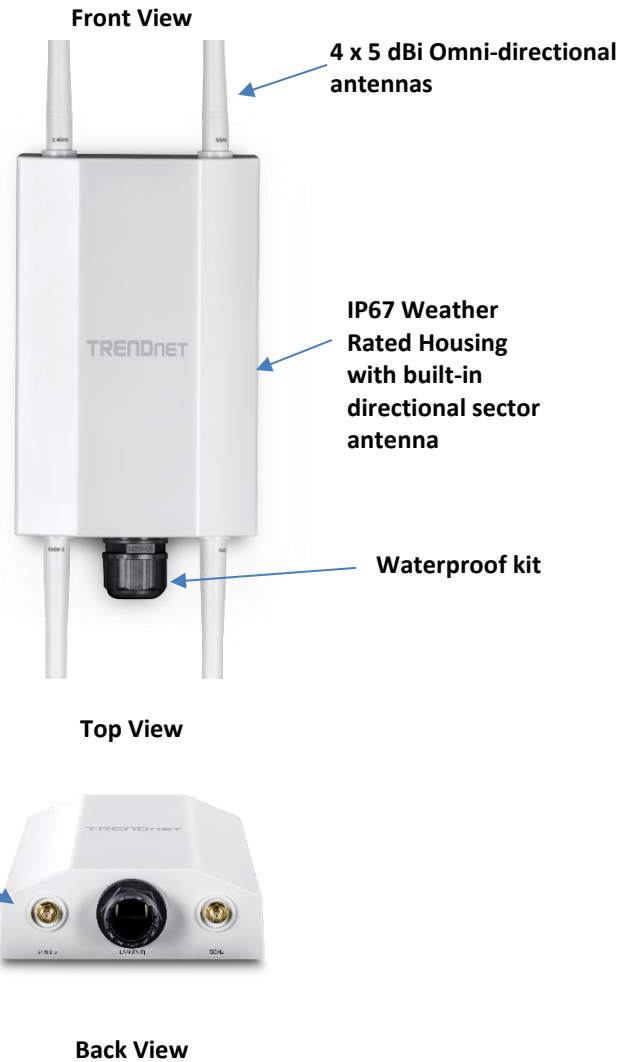

LED Indicators



- **4 x RP-SMA (female) antenna connectors** – The access point ships with 4 x 5dBi Omni directional antennas. Please take note to connect the correct antenna, the antennas are tuned for optimizations on their labeled wireless bands.
- **Waterproof kit** – The access point comes with a waterproof cable guard for outdoor installations.
- **Mounting Point** – The access point can be wall or pole mounted using the mounting points on the unit, and the mounting kit included with the packaging.
- **PoE+ 2.5 Gigabit LAN port (power input)** – This gigabit Ethernet interface will be used to power the access point using standard 802.11at PoE+ power source and provide gigabit network connectivity to the access point.
- **Power (PWR) LED** – When the LED is ON, this will indicate that the device is receiving power and OFF if the device is not receiving power.
- **LAN LED** – When the LED is ON, this indicates an active network connection to the LAN port on the proprietary PoE injector. When the LED is BLINKING, this indicates data is being transmitted or received on the LAN port.
- **2.4GHz LED** – When the LED is ON, the wireless radio on the device is on. When the LED is OFF, the wireless radio on the device has been disabled.
- **5GHz LED** – When the LED is ON, the wireless radio on the device is on. When the LED is OFF, the wireless radio on the device has been disabled.

Important Note:

It is recommended to use RJ-45 cables without any additional caps, molded caps, or boots specifically on the connector side that will be connected to the access point LAN1 (PoE) port to avoid any cable fitment issues.

Primary Product Application

The intended purpose and application for this product is to extend network connectivity across long physical distances outside of an area or building that lacks local connectivity using point-to-point or point-to-multipoint wireless bridging using 802.11 standards. This allows two access points configured in point-to-point bridge capability can connect/link the two physical locations or buildings together through an encrypted wireless connection.

Although this product supports multiple wireless modes, the basic installation will only cover the primary application of point to point wireless connectivity in WDS (Wireless Distribution System) Mode using AES encryption for security.

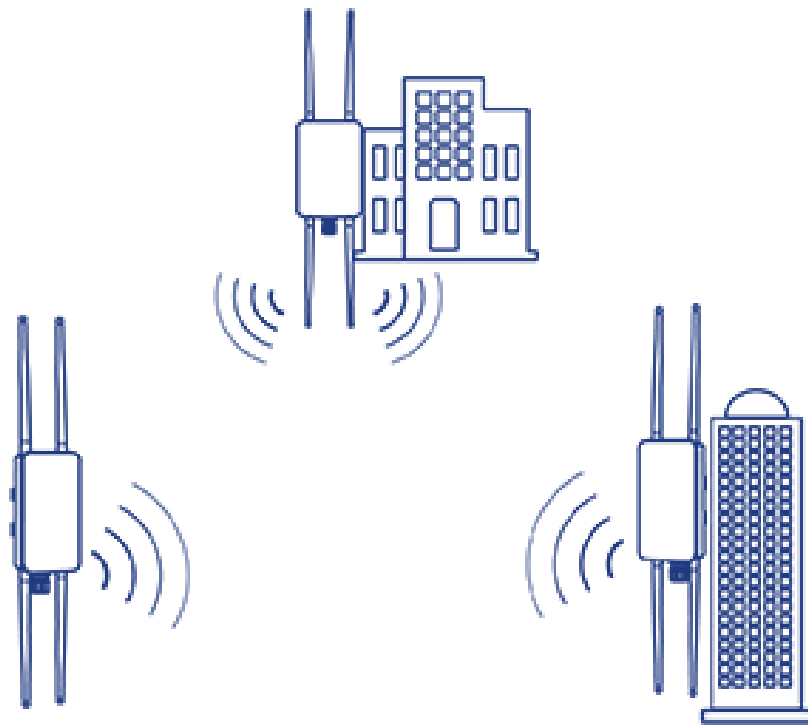

Application Diagram

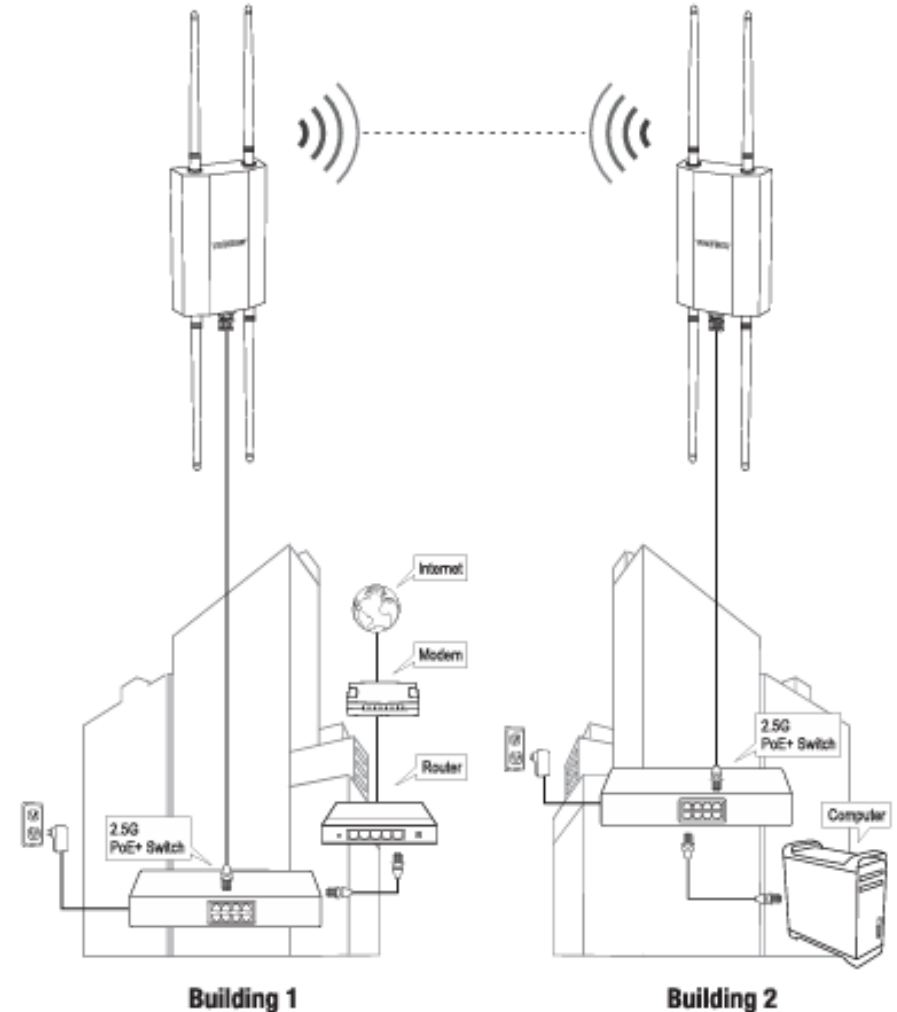

The example application displays two TEW-941APBO access points establishing a wireless link between each other, both configured in WDS Bridge; allowing for network connectivity between two buildings over a point-to-point wireless link.

Minimum Installation Requirements

- Computer with RJ-45 Ethernet port and web browser
- RJ-45 Ethernet cables (not included)
- Additional TRENDnet TEW-941APBO or TEW-940APBO (optional for point-to-point bridging)
- Flat head screwdriver for pole mounting clamp

For wall mounting only (included wall mounting kit for drywall installations only)

- Philips driver bit or screwdriver
- Power drill/driver (for mounting anchors)
- 7/16 in (2.75 mm) straight drill bit for hard wood or 3/32 in (2.35 mm) bit for soft wood (for mounting screws)
- 11/16 in (4.3 mm) straight drill bit for hard wood or 5/32 in (4 mm) bit for soft wood (if required for drywall anchors)

Note: The access point complies with IEEE 802.3at Power over Ethernet (PoE+) standard and can be used with other 802.3at PoE+ switches or injectors to deliver both power and data to the access point through the network LAN (PoE) port.

IMPORTANT NOTE: This device does not have a hardware reset button. When changing the administrator password to the access point configuration page, please make sure to write down your new password.

Wireless Installation Tips

There are a number of factors that can impact the range of wireless devices.

1. Adjust your wireless devices so that the signal is traveling in a straight path, rather than at an angle. The more material the signal has to pass through the more signal you will lose.
2. Keep the number of obstructions to a minimum. Each obstruction can reduce the range of a wireless device. Position the wireless devices in a manner that will minimize the amount of obstructions between them.
3. Building materials can have a large impact on your wireless signal. In an indoor environment, try to position the wireless devices so that the signal passes through less dense material such as dry wall. Dense materials like metal, solid wood, glass or even furniture may block or degrade the signal.
4. Antenna orientation can also have a large impact on your wireless signal. Use the wireless adapter's site survey tool to determine the best antenna orientation for your wireless devices.
5. Interference from devices that produce RF (radio frequency) noise can also impact your signal. Position your wireless devices away from anything that generates RF noise, such as microwaves, radios and baby monitors.

If you are still experiencing low or no signal consider repositioning the wireless devices or installing additional access points. The use of higher gain antennas may also provide the necessary coverage depending on the environment. Please note to use the wireless connection quality indicators during installation to determine the optimal positioning when mounting your access points.

Quick Reference

TEW-941APBO

Note: By default, the wireless network name/SSID and wireless encryption settings have been pre-configured for your convenience and can be located on the included preset wireless sticker. The access point web management configuration page can be accessed using the URL <http://tew-941APBO> or using the LAN IP address of the device. The IP address settings by default is set to DHCP, but if no DHCP server is present on the network, then it will default to <http://192.168.10.100>.

Important Note:

Purchasing this model requires the access points to be properly configured to establish the wireless link/bridged connection to each other and verifying connectivity first before mounting the access points in their desired locations.

Default Settings

http://tew-941APBO
 LAN IP Address: 192.168.10.100 (DHCP)
 LAN Subnet Mask: 255.255.255.0
 Channel Access Method: CSMA/CA
 Mode: Access Point (AP) Mode
 WPA2 Encryption Key: <predefined>
 User: admin
 Password: admin

Preset Wireless Settings	
Wi-Fi Name/SSID [AX/ AC/ N/ A] TRENDnet941_5GHz_XXXX [AX/ N/ B/ G] TRENDnet941_2.4GHz_XXXX	
Wi-Fi Password 941XXXXXXXXX	
Management Login http://tew-941apbo username: admin password: admin	

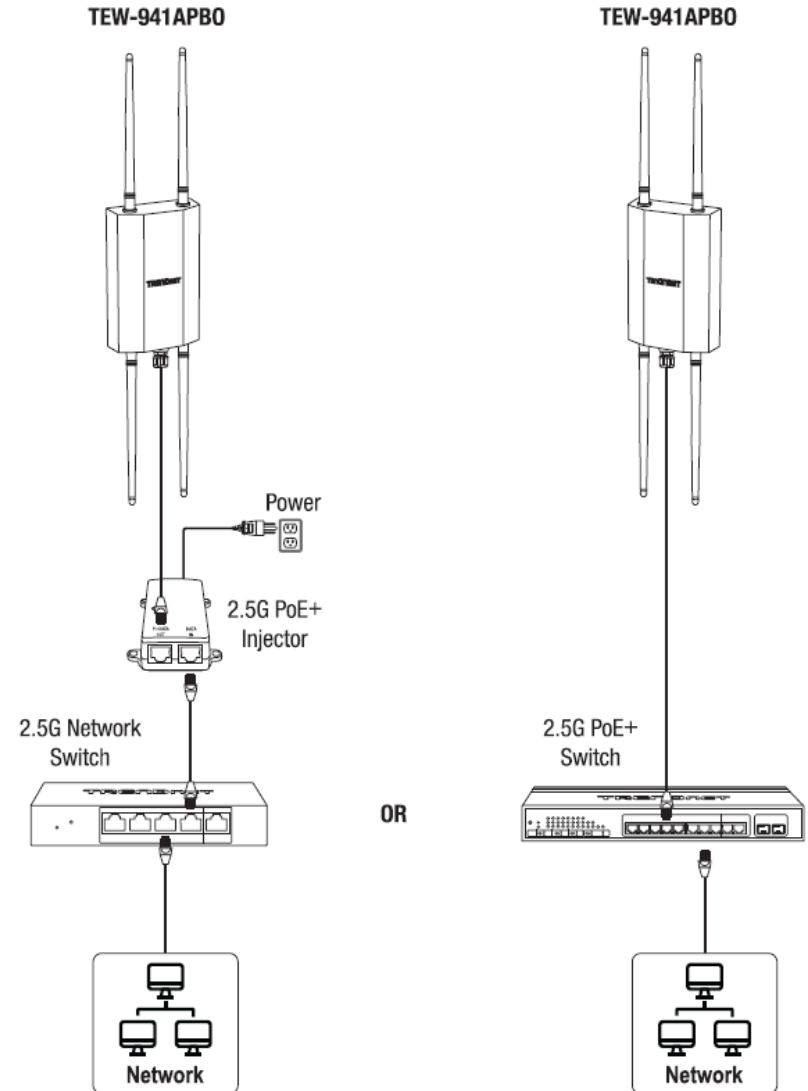

TEW-941APBO Basic Installation and Configuration (Basic Access Point Setup)

The following installation procedure is for setting up the TEW-941APBO as a basic outdoor Omni-directional access point.

Hardware Setup

1. Attach the antennas as shown in the following image.

NOTE: There are two different sets of antennas, one tuned for 2.4GHz, the other tuned for 5GHz. **Be sure to attach each antenna to its respective band for optimal performance.**

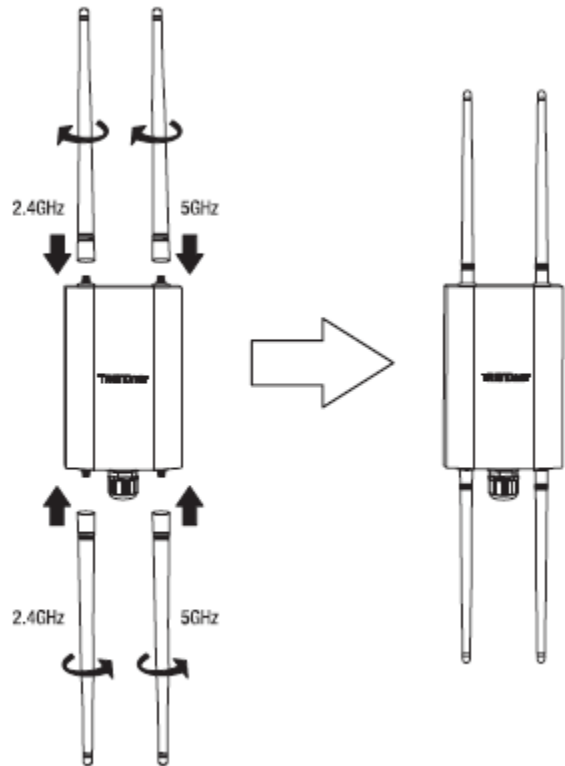

Basic Access Point Configuration

Note: It is strongly recommended to configure the access point first, prior to mounting.

1. Using a RJ-45 network cable, connect the cable from the LAN (PoE) port of your access point, to an available LAN PoE+ port on your networked switch or PoE+ injector.
2. Using another RJ-45, connect your computer's Ethernet port to the same PoE+ device chosen in step 1.

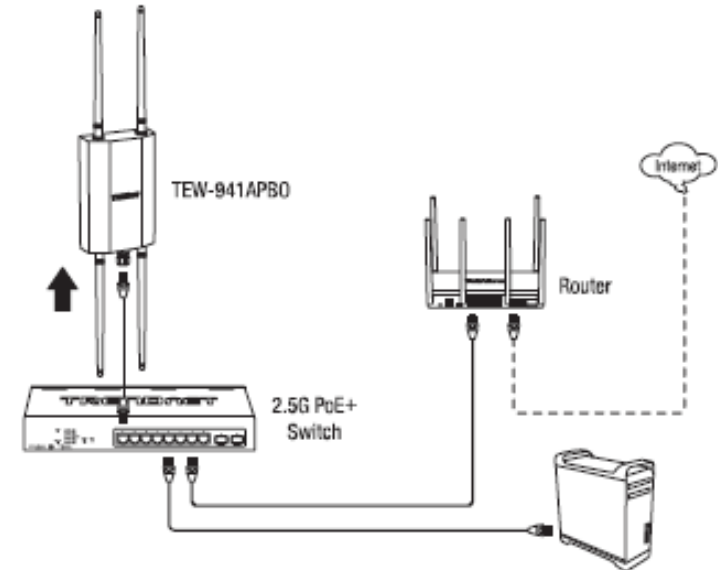

3. Confirm the device is powered on through the LED indicators.

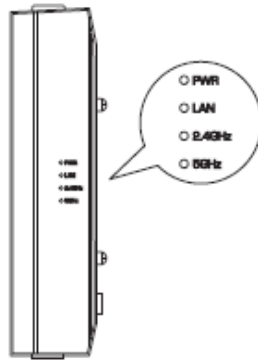

- Assign a static IP address to your computer's network adapter in the subnet of 192.168.10.x (e.g. 192.168.10.10) and subnet mask of 255.255.255.0.

Note: For information on how to statically assign your IP address, see the Appendix section.

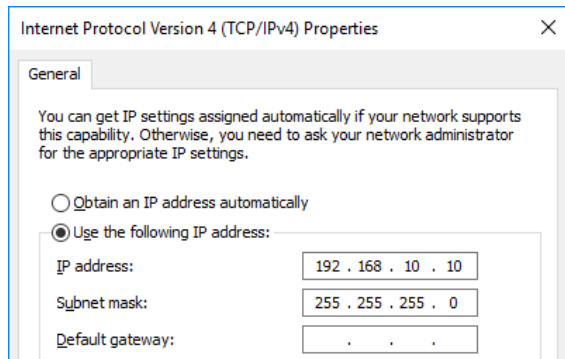

- Open your web browser and type in the default IP address of the access point in the address bar, then press **Enter**. The default IP address of the access point is 192.168.10.100.

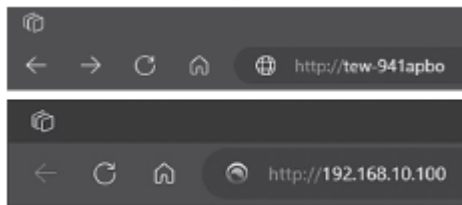

- When prompted, login to the access point management page using the default user name and password settings.
 - User Name: admin
 - Password: admin

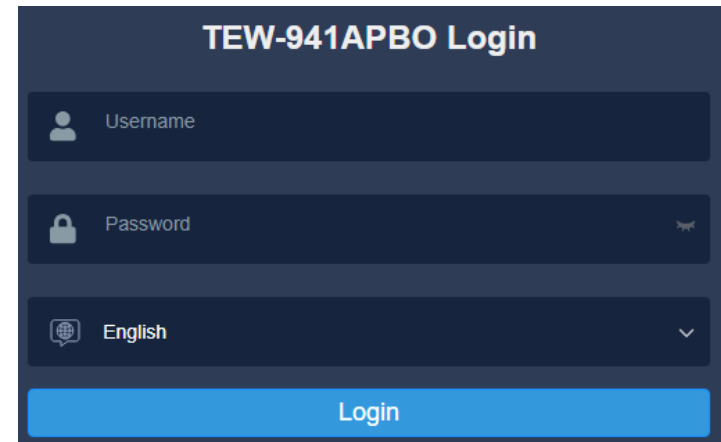

Wizard

- For the first-time logging into the device the setup wizard will start automatically.
- For your security, the first step is to change the login password of the access point. Enter your new login password and click apply.

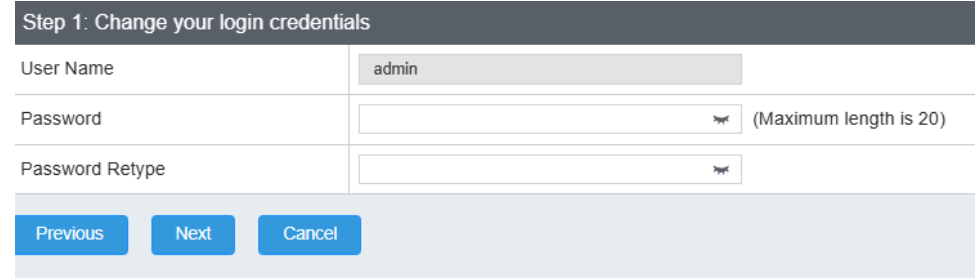

- Your new password settings will be applied. In the next screen, select the method of management for this AP. To manage the AP from the cloud remotely choose **TRENDnet Hive** (additional fees may apply). To manage the AP through your local GUI, choose **Default Management**.

Step 2: Select the method of management for this AP

TRENDnet Hive: Choose this option if you would like to manage your AP through TRENDnet's Cloud Management. This option will automatically apply a DHCP connection (Dynamic IP Address) to your AP.
Note: You will need a TRENDnet Hive account with a valid license to complete setup with this process. Choosing this option will prompt an immediate re-login to the device management page.

Default Management: Choose this option if you would like to manage your AP through the local GUI. You may opt in to use TRENDnet Hive at a later date. Please note, by default the AP is configured to automatically obtain IP address settings from a DHCP server connected to your network. If there is no DHCP server available, the IP address of the AP will be set to 192.168.10.100/255.255.255.0.

TRENDnet Hive Installation method

1. Select the time zone from the drop-down menu and click **Next** to move to the next screen.

Step 3: Date/Time Settings

Current Time	Thu Jun, 1, 2023 00:02:19
Time Zone	GMT-08:00 Pacific Time (US Canada), Tijuana

2. Input your TRENDnet Hive **User Name** and **Password**. Click Next to move to the next step.

Step 4: Input your Hive credentials to sync the AP to your Hive account.

User Name	trendnet
Password	*****

3. Review the settings and click **Apply**. Your device will save the changes and reboot.

System Information

Write down the above information and store it in a safe place. The below information are the current settings that will be applied to the AP. Click **Apply** below to finalize the settings.

System Time	Thu Jun, 1, 2023 00:01:24
User Name	admin
Password	*****
IP Address	192.168.10.104
Subnet Mask	255.255.255.0
Gateway IP Address	192.168.10.254
DNS1	192.168.1.249
DNS2	8.8.8.8

IMPORTANT NOTE: This device does not have a hardware reset button. When changing the administrator password to the access point configuration page, please make sure to write down your new password.

TRENDnet Default Management Method

1. Manually input the time and date settings and click **Next** to move to the next screen.

Step 3: Date/Time Settings

Current Time	Thu Jun, 1, 2023 00:02:01		
Date Settings	Year: 2024	Month: Jun	Day: 01
Time Settings	Hour: 13	Minutes: 01	Second: 00

2. Input your network configurations and click **Next**.

Step 4: Input your IP settings in the fields below

IP Address	192.168.10.104
Subnet Mask	255.255.255.0
Gateway IP Address	192.168.10.254
DNS1	192.168.1.249
DNS2	8.8.8.8

3. Review the settings assigned and click **Apply** to save the settings to your AP.

System Information

Write down the above information and store it in a safe place. The below information are the current settings that will be applied to the AP. Click **Apply** below to finalize the settings.

System Time	Thu Jun, 1, 2023 00:01:24
User Name	admin
Password	***** 
IP Address	192.168.10.104
Subnet Mask	255.255.255.0
Gateway IP Address	192.168.10.254
DNS1	192.168.1.249
DNS2	8.8.8.8

IMPORTANT NOTE: This device does not have a hardware reset button. When changing the administrator password to the access point configuration page, please make sure to write down your new password.

Hardware and Mounting Installation

Waterproof Kit Installation

1. Unscrew the sealing nut from the main body and remove the placeholder center pin.
2. Separate the rubber seal from the claw.
3. Verify that you have the following parts:



4. Insert one end of an Ethernet cable into the sealing nut.

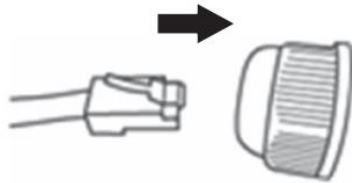

5. Insert the Ethernet cable into the seal.

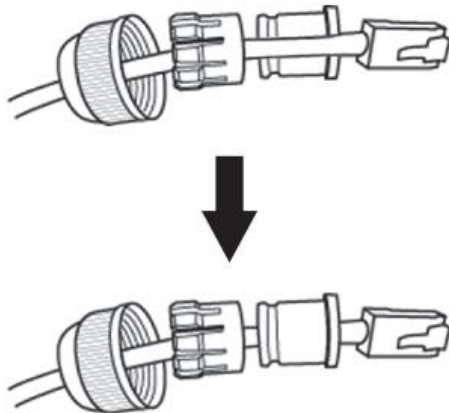

6. Insert the seal into the claw.

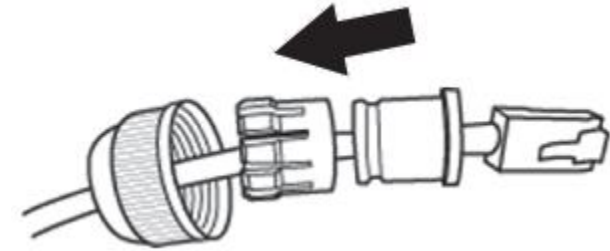

7. Insert the seal+rubber claw into the Cable Gland.

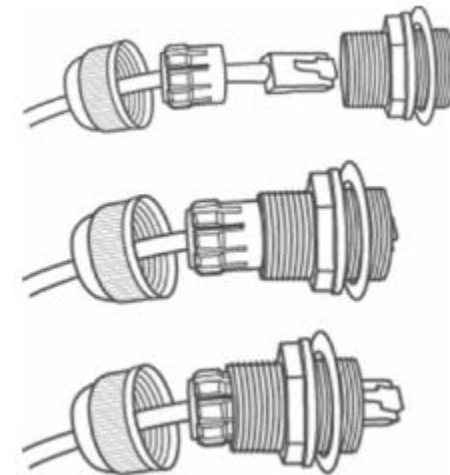

8. Connect the Ethernet cable to the LAN (PoE) port on the bottom of the access point.

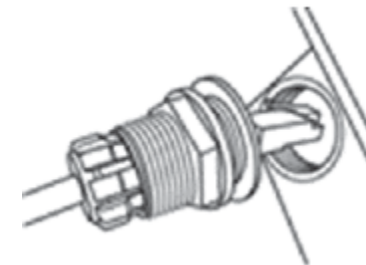

9. By hand, screw the main body of the seal counter clockwise to secure it to the access point.

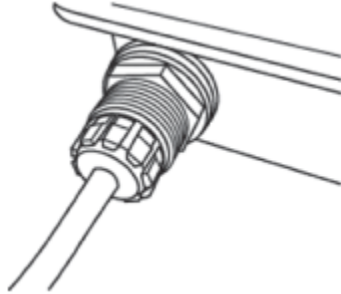

10. By hand, screw the seal nut clockwise to secure it to the main body.



Pole Mount Installation

Note: The pole mounting clamp supports poles with a maximum diameter of 66 mm (2.63 in.)

1. Install the metal mounting bracket by aligning the four bracket points to the four mounting holes on the back of the access point. The hole for the mount bracket locking screw should be located at the top right when installing the mounting bracket to the access point.

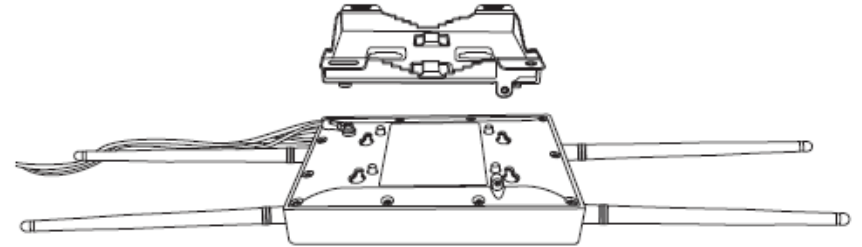

2. After installing the mounting bracket to the back of the access point, slide the mounting bracket left and install the locking screw by turning clockwise.

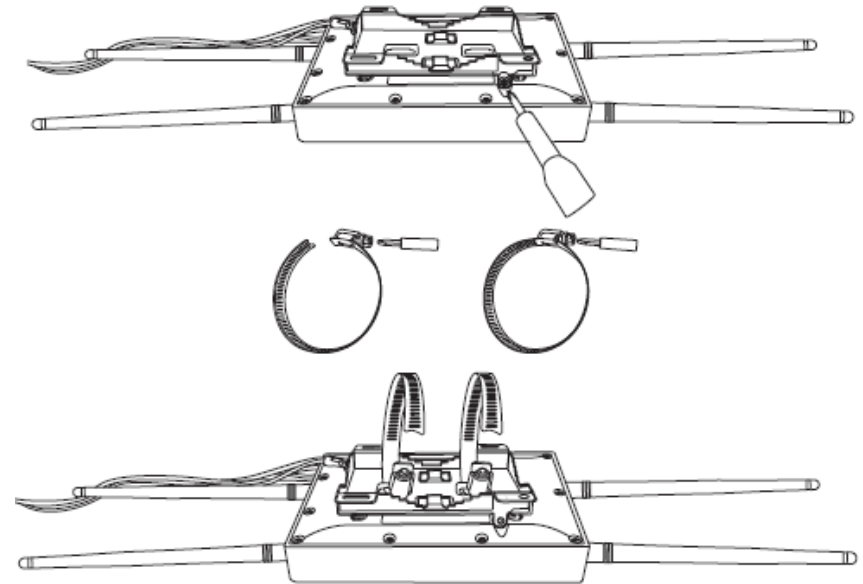

Application Modes

Although the access point is intended to be used for primarily WDS point-to-point bridging, the access point offers other operating modes. The access point's multiple mode system can be configured either in client bridge mode or as an access point. It also can be used as a WDS (Wireless Distribution System) node for Ethernet network expansion. This section explains the different modes the device has available, **Access Point (AP), Client Bridge, and Repeater**.

The different operation modes can be found under **System > Operation Mode** in the access point web management page.

Note: The model used in the artwork below may appear different than your unit.

Access Point (AP)

An **access point** can be either a main, relay or remote base station. A main base station is typically connected to a wired network via an Ethernet port. A relay base station relays data between main base stations and relay stations or remote base stations with clients. A remote base station is the end point to accept connections from wireless clients and pass data upstream to a network wirelessly.

Example: Access Point

- It can be deployed as a traditional fixed wireless access point.

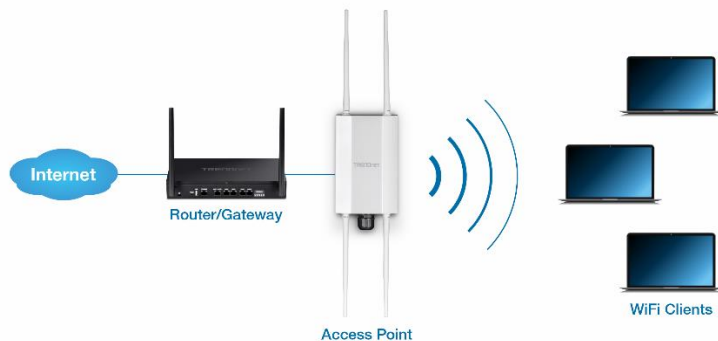

Client Bridge

Client bridge mode enables the device to essentially act as a wireless client while bridging with the LAN port on the device. In this mode, the AP functions similarly to that of a wireless client or station such as mobile phone, tablet, or notebook computer. The wired port LAN (PoE) is logically bridged to the wireless interface. The clients of the remote access point are in the same subnet from Main Base.

Example: AP with Client Bridge mode

- It can be deployed as a wireless client (with wired LAN) to a wireless access point.

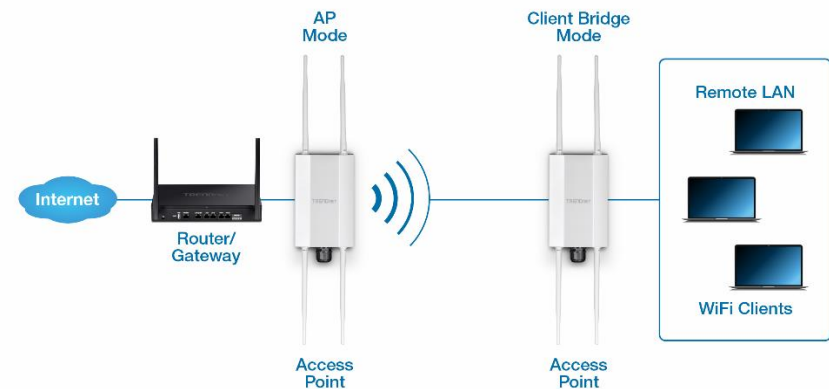

Repeater

Repeater mode lets the unit to repeat wireless signal and packets for backbone communication as well as client access. This feature is used to expand your existing wireless network to areas that your current access point is unable to reach. Make sure all of the settings of the wireless interface matches to your root or connecting wireless access points, same SSID, channel and wireless encryption settings.

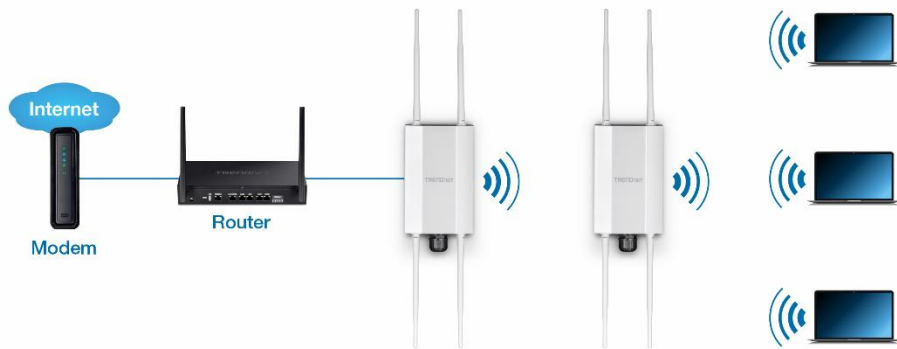

Accessing your access point management page

Access your access point management page

Note: Make sure your access point is powered on using an IEEE 802.3at PoE+ switch or injector and your computer is connected to the same network as that switch or injector. Using your Internet web browser (e.g. Internet Explorer®, Firefox®, Chrome™, Safari®, Opera™), your AP's management page may be accessed at its domain name registration <http://tew-941APBO>, default IP address <http://192.168.10.100> (when no DHCP server present), or the IP address assigned by your DHCP server. The TEW-941APBO by default is configured with DHCP IP settings. Additionally, this information is printed on the wireless sticker and device label located on the back of the access point enclosure.

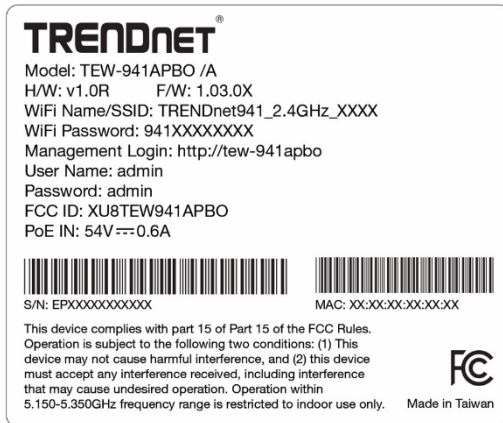
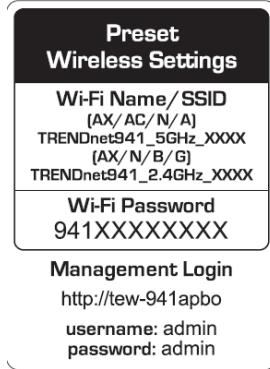

If the access point is connected to a network with an active DHCP server, the access point will be assigned an IP address by your DHCP server. Check your DHCP server's client list for the assigned IP address.

If the initial configuration of the access point is done on an isolated network, the default IP address is <http://192.168.10.100>. Assign a static IP address to your computer's network adapter in the subnet of 192.168.10.x (e.g. 192.168.10.10) and subnet mask of 255.255.255.0.

If you have changed the default IP address, you will need to ensure that your computer is configured with IP address settings in the same subnet as the as the access point in order to access the management page. (Ex. Access Point IP address changed to 192.168.0.100 / 255.255.255.0, example computer address 192.168.0.25 / 255.255.255.0).

Alternatively, you may also use the default domain name <http://tew-941APBO>.

1. Open your web browser and go to the address <http://192.168.10.100>, <http://tew-941APBO>, or the IP address that has been assigned to the access point. Your access point will then prompt you for a user name and password.

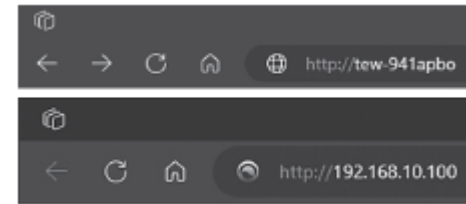

2. By default, the user name is *admin* and password is *admin*. Enter your **Username** and **Password**, then click **Login**.

Note: If you have changed the password, you will need to login using the new password. User Name and Password are case sensitive.

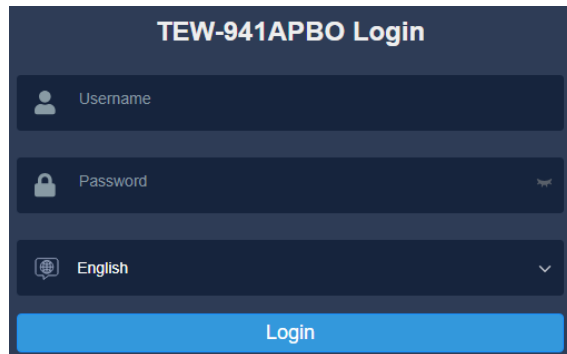

TEW-941APBO Login

Username

Password

English

Login

Overview

Device Status

Dashboard

This page will display the AP system summary information such as the device name, serial number, system time, firmware version, MAC, IPv4/IPv6 address settings, WiFi information, etc.

1. Log into your access point management page (see “[Access your access point management page](#)” on page 27).
2. Click on **Device Status** from the left side menu. To refresh the page, click **Refresh** at the bottom of the page.

System Information & Network

- **Device Name** – Displays the identifying device name of your access point. This information can be modified under the **Management > System Management** section.
- **Firmware Version** – Displays the current firmware of the access point
- **System Time** – Displays the current time assigned to the access point. This information can be modified under the **System > Time and Date Settings** section.
- **System Uptime** – Displays the time the access point has been powered on.
- **MAC Address**– Displays the MAC address for the access point’s LAN, and both WLAN radios.
- **IP Address** – Displays the IPv4 address assigned to the access point. This can be modified under the **System > IP Settings** section.
- **Subnet Mask** – Displays the current IPv4 subnet mask assigned to your access point.
- **Default Gateway** – Displays the current gateway address assigned to your access point.
- **Primary Domain Name Server** – Displays the primary Domain Name Server (DNS) assigned to your access point.
- **Secondary Domain Name Server** – Displays the secondary Domain Name Server (DNS) assigned to your access point.

System Information		Network	
Device Name	TEW-941APBO	MAC Address	78:2D:7E:23:75:7E
Firmware Version	1.0.3.06	IP Address	192.168.10.104
System Time	Thu Jun, 1, 2023 21:17:00	Subnet Mask	255.255.255.0
System Up Time	0 Day, 21:17:57	Default Gateway	192.168.10.254
		Primary Domain Name Server	8.8.8.8
		Secondary Domain Name Server	8.8.4.4

Usage

- **Most Used SSID** – Displays the most active SSID based off of the amount of traffic passing through
- **Most Active Client** – Displays the device name that is the most active based off of the amount of traffic passing through
- **All-time Top Client** – Displays the device name that has used the most data overall based off of the amount of traffic passing through

Usage	
Most Used SSID	- ↓ 0.00 B ↑ 0.00 B
Most Active Client	- ↓ 0.00 B ↑ 0.00 B
All-time Top Client	- ↓ 0.00 B ↑ 0.00 B

Wireless LAN Information – 2.4GHz

- **Operation Mode** – Displays the operation mode that the access point is currently set.
- **Wireless Mode** – Displays the IEEE 802.11 protocol the access point's wireless radio is broadcasting on.
- **Channel Width** – Displays the channel width currently used in 2.4GHz radio

- **Frequency (Channel)** – Displays the channel that the 2.4GHz radio is using.
- **TX (Packets)** – Displays the amount of data being transmitted from the 2.4GHz radio
- **RX (Packets)** – Displays the amount of data being received from the 5GHz radio
- **SSID** – Displays the SSID name of the 2.4GHz radio
- **MAC Address** – Displays the MAC address of the 2.4GHz radio
- **Security Mode** – Displays the encryption type for 2.4GHz radio
- **Status** – Displays if the radio is on or off for the 2.4GHz radio

2.4GHz Wireless

Operation Mode	Access Point
Wireless Mode	802.11 ax
Channel Width	HT20
Frequency (Channel)	CH1 - 2.412GHz
TX (Packets)	0.00B (0 PKts.)
RX (Packets)	0.00B (0 PKts.)

SSID List

SSID	MAC Address	Security Mode	Status
TRENDnet941_2.4GHz_757E	78:2D:7E:23:75:7F	WPA3-Personal Mixed	ON

Wireless LAN Information – 5GHz

- **Operation Mode** – Displays the operation mode that the access point is currently set.
- **Wireless Mode** – Displays the IEEE 802.11 protocol the access point's wireless radio is broadcasting on.
- **Channel Width** – Displays the channel width currently used in 5GHz radio
- **Frequency (Channel)** – Displays the channel that the 5GHz radio is using.
- **TX (Packets)** – Displays the amount of data being transmitted from the 5GHz radio
- **RX (Packets)** – Displays the amount of data being received from the 5GHz radio
- **SSID** – Displays the SSID name of the 5GHz radio
- **MAC Address** – Displays the MAC address of the 5GHz radio
- **Security Mode** – Displays the encryption type for 5GHz radio
- **Status** – Displays if the radio is on or off for the 5GHz radio

5GHz Wireless

Operation Mode	Access Point
Wireless Mode	802.11 ax
Channel Width	HT80
Frequency (Channel)	CH36 - 5.18GHz
TX (Packets)	0.00B (0 PKts.)
RX (Packets)	0.00B (0 PKts.)

SSID List

SSID	MAC Address	Security Mode	Status
No Data Available			

CPU & Memory Utilization

- This section displays the access point's memory or RAM and CPU usage status.

CPU & Memory Utilization

CPU	Used	17%
	Idle	83%
Memory	Total	392736 KB
	Free	249392 KB
	Used	143344 KB

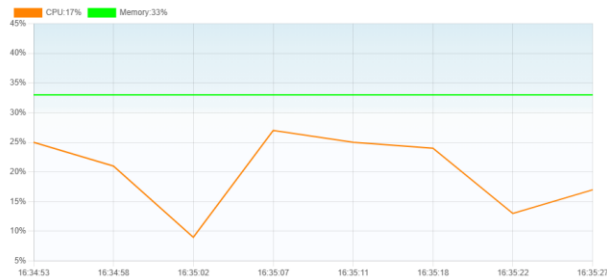

Total Clients & Total Throughput

- This section displays the total clients connected to the access point and the throughput over time.

Total Clients

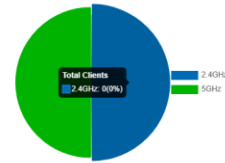

Total Throughput

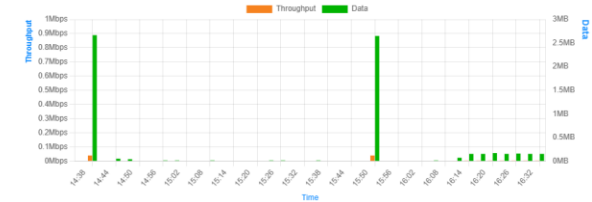

2.4GHz Wireless/5GHz Wireless Status

Dashboard > 2.4GHz Wireless / 5GHz Wireless

This section displays the current usage of each wireless radio

- No. of Clients** – displays the number of clients currently connected to this radio band
- Traffic** – displays the current traffic throughput of this radio band
- Data** – displays the amount of data being sent through this radio band
- Device Name** – displays the name of the client connected to this radio band
- MAC Address** – displays the mac address of the client
- SSID** – displays the SSID the device is connected to
- RSSI** – displays the RSSI signal strength
- Download / Rate** – displays the amount of data downloaded and the connection speed
- Upload / Rate** – displays the amount of data uploaded and the connection speed
- 802.11 Mode** – displays the 802.11 standard that the client is connected to
- History** – clicking on this will display the history of the device connected to this radio band
- Time** – displays how long the device has been connected to this radio band
- Action** – Click on **Blacklist** will ban this device from accessing this radio band

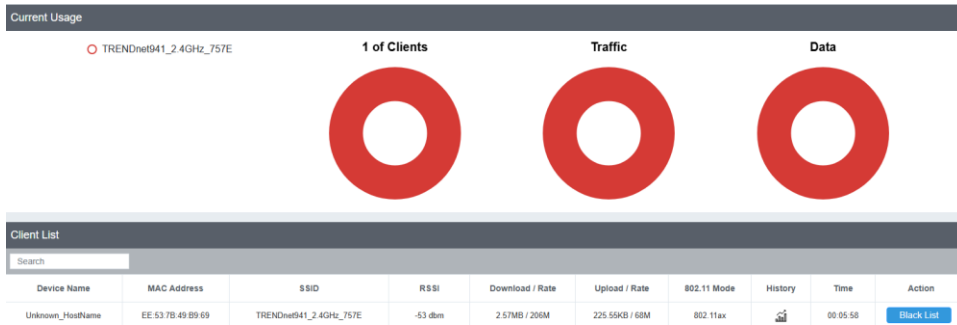

System Log

Dashboard > System Log

This section contains the system logs for troubleshooting.

1. Log into your access point management page (see "[Access your access point management page](#)" on page 27).
2. Click on **Dashboard** under **System Log** from the left side menu.

System Log

- **Refresh** – Click **Refresh** to refresh the logs.
- **Clear** – Click **Clear** to clear the logs.

System log

```
Thu Jun 1 01:22:43 2023 daemon.info HTTP: [admin] login
Thu Jun 1 00:04:11 2023 daemon.info HTTP: [admin] login
Thu Jun 1 00:00:43 2023 daemon.info SSH: stopping service.
Thu Jun 1 00:00:43 2023 daemon.info SSH: stopping service.
Thu Jun 1 00:00:23 2023 daemon.info UPnP: stopping service.
Thu Jun 1 00:00:14 2023 daemon.info UPnP: stopping service.
Thu Jun 1 00:00:01 2023 daemon.info SNMP: starting service.
Thu Jun 1 00:00:01 2023 daemon.info UPnP: stopping service.
```

Refresh

Clear

System Log

Dashboard > IPv6 Status

1. Log into your access point management page (see "[Access your access point management page](#)" on page 27).
2. Click on **Dashboard** under **IPv6 Status** from the left side menu.

IPv6 Status

- **IPv6 Connection Type** – Displays the type of IPv6 connection type
- **IPv6 IP Address** – Displays the IPv6 IP Address
- **LAN IPv6 Link-Local Address** – Displays the IPv6 Link Local Address
- **IPv6 Default Gateway** – Displays the IPv6 address of the default gateway
- **Primary IPv6 DNS Server** – Displays the primary DNS Server in IPv6 Address
- **Secondary IPv6 DNS Server** – Displays the secondary DNS server in IPv6 Address

Network	
IPv6 Connection Type	Autoconfiguration (SLAAC/DHCPv6)
IPv6 IP Address	-
LAN IPv6 Link-Local Address	fe80::7a2d:7eff:fe23:757e/64
IPv6 Default Gateway	-
Primary IPv6 DNS Server	-
Secondary IPv6 DNS Server	-

System

IP Settings

System > IP Settings

This page allows configuration of the access point's IPv4, IPv6, and Spanning Tree Protocol settings.

1. Log into your access point management page (see "[Access your access point management page](#)" on page 27).
2. Click on **IP Settings** under **System** from the left side menu. Please note, when clicking **Save**, the settings are saved but not applied yet.

IPv4 Settings

- **Connection Type** – Select either **DHCP** or **Static IP**. *Default: DHCP*
- **IP Address** – Enter the desired IPv4 address if above setting is set to static IP.
- **Subnet Mask** – Enter the desired IPv4 subnet mask.
- **Default Gateway** – Enter the desired IPv4 Gateway.
- **Primary DNS** – Enter the desired primary Domain Name Server (DNS).
- **Secondary DNS** – Enter the desired secondary Domain Name Server (DNS).

LAN Connection Type

Connection Type	DHCP ▼
-----------------	---

DNS Server Setting

Primary DNS Server	8.8.8.8
Secondary DNS Server	8.8.4.4

Apply
Cancel

3. Click **Apply** to apply the settings and click **Save** the changes permanently to the flash by clicking the **Save** button in the top right corner.

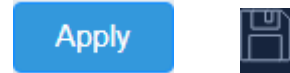

IPv6 Settings

System > IPv6 Settings

1. Log into your access point management page (see "[Access your access point management page](#)" on page 27).
2. Click on **IPv6 Settings** under **System** from the left side menu. Please note, when clicking **Save**, the settings are saved but not applied yet.
 - **Autoconfiguration (SLAAC/DHCPv6)** – automatically configure IPv6 address
 - **Static IPv6** – Configure the IPv6 with a static address
 - **Local Connectivity Only** – Set the IPv6 for local access only
 - **LAN IPv6 Address** – Input the IPv6 address for LAN access
 - **Subnet Prefix Length** – Input the subnet address for IPv6
 - **Default Gateway** – Set the IPv6 address of the default gateway
 - **Primary / Secondary DNS Server** – Input the IPv6 address for the DNS server
 - **Link-local Address** – Check the box to enable IPv6 Link-local Address setting.
 - **IP Address** – Enter the desired IPv6 address.

IPv6 Connection Type

My IPv6 Connection is

Note: Choose the mode to be used by the AP to connect to the IPv6 Internet.

IPv6 DNS SETTINGS

DNS server access method

Primary DNS Server

Secondary DNS Server

Note: Obtain DNS server address automatically or enter a specific DNS server address.

Apply

Cancel

3. Click **Apply** to apply the settings and click **Save** the changes permanently to the flash by clicking the **Save** button in the top right corner.

Apply



Cloud Settings (Hive)

System > Cloud Settings

This section allows you to setup your device for TRENDnet's Cloud Management (Hive). With TRENDnet Hive, you will be able to manage and monitor your device through the TRENDnet Cloud portal remotely.

1. Log into your access point management page (see "[Access your access point management page](#)" on page 27).
2. Click on **Cloud Settings** under **System** from the left side menu. Please note, when clicking **Save**, the settings are saved but not applied yet.

3. Select **Enabled** on Cloud Mode to enable TRENDnet Hive settings, or **Disable** to disable it.

Cloud Settings

Cloud Mode

4. Enter your TRENDnet Hive account username and password.

Note: Connecting your device to the cloud will lock all configurations to be managed by the cloud. To configure your device locally, please **Disable** your connection to the cloud.

Spanning Tree Protocol (STP) Settings

System > Spanning Tree Settings

1. Log into your access point management page (see "[Access your access point management page](#)" on page 27).
2. Click on **System** under **Spanning Tree Settings** from the left side menu. Please note, when clicking **Save**, the settings are saved but not applied yet.
 - **Spanning Tree Status** – Select either to **Enable** or **Disable** STP. *Default: Disabled*
 - **Bridge Hello Time** – Enter the desired hello time (in seconds)
 - **Bridge Max Age** – Enter the desired max age (in seconds).
 - **Bridge Forward Delay** – Enter the desired forward delay (in seconds).
 - **Priority** – Enter the desired priority of this STP configuration.

Spanning Tree Protocol (STP) Settings

Status	<input type="radio"/> Enable <input checked="" type="radio"/> Disable
Hello Time	<input type="text" value="2"/> seconds (1-10)
Max Age	<input type="text" value="20"/> seconds (6-40)
Forward Delay	<input type="text" value="15"/> seconds (4-30)
Priority	<input type="text" value="32768"/> (0-65535)

3. Click **Apply** to apply the settings and click **Save** the changes permanently to the flash by clicking the **Save** button in the top right corner.



Band Steer

System > Band Steer

Band steer alleviates network congestion by redirecting wireless client from 2.4GHz band to the 5GHz band.

1. Log into your access point management page (see "[Access your access point management page](#)" on page 27).
2. Click on **Band Steer** under **System** from the left side menu. Please note, when clicking **Save**, the settings are saved but not applied yet.
3. Select **Enabled** to enable band steering or **Disabled** to disable this feature.

Band steering

Status

4. Click **Apply** to apply the settings and click **Save** the changes permanently to the flash by clicking the **Save** button in the top right corner.



Airtime Fairness

System > Airtime Fairness

Airtime Fairness focuses on scheduling fairness for transmission of traffic from the Access Point and efficient WiFi bandwidth utilization.

1. Log into your access point management page (see "[Access your access point management page](#)" on page 27).
2. Click on **Band Steer** under **System** from the left side menu. Please note, when clicking **Save**, the settings are saved but not applied yet.
3. Select **Enabled** to enable band steering or **Disabled** to disable this feature.

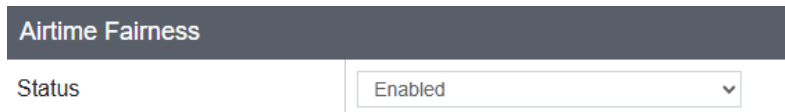

4. Click **Apply** to apply the settings and click **Save** the changes permanently to the flash by clicking the **Save** button in the top right corner.



Management VLAN

System > Airtime Fairness

1. Log into your access point management page (see "[Access your access point management page](#)" on page 27).
2. Click on **Management VLAN** under **System** from the left side menu. Please note, when clicking **Save**, the settings are saved but not applied yet.
 - **Status** – Select **Enabled** to enable VLAN isolation or **Disabled** to disable it

- **VID** – Input the VLAN ID in the SSID profile, all traffic associated with this SSID will be tagged with this VLAN ID upon entering the LAN Bridge.

2.4GHz Current Profiles			
Status	VID	SSID	WiFi Security
Disabled		TRENDnet941_2.4GHz_757E	WPA3-Personal Mixed

3. Select **Specified VLAN ID** to enable Management VLAN.
 - When enabled with a specified VLAN ID, the device will only allow management interface access with the specified VLAN ID.

Management VLAN Settings	
Management VLAN ID	Specified VLAN ID <input type="text" value="1"/> (must be in the range 1 ~ 4092.)

4. Click **Apply** to apply the settings and click **Save** the changes permanently to the flash by clicking the **Save** button in the top right corner.



Time and Date Settings

System > Time and Date Settings

This section allows you to configure the access point time and date settings.

1. Log into your access point management page (see "[Access your access point management page](#)" on page 27).
2. Click on **Time and Date Settings** under **System** from the left side menu. Please note, when clicking **Save**, the settings are saved but not applied yet.

Time Configuration

- **System Time** – Displays the current date and time based off the settings
- **Time Zone** – Select the time zone the unit is located in

Time Configuration	
System Time	Thu Jun, 1, 2023 04:38:57
Time Zone	GMT-08:00 Pacific Time (US Canada), Tijuar

Date and Time Settings

- **Local Time** – Select this option to manually enter the date and time settings.,
- **SNTP** – Select this option to have the date and time retrieve from a SNTP server.
 - **NTP Server** – Select the NTP server from the drop down list
 - **NTP synchronization** – Input the time of how often the device will check with the NTP server

Date/Time Settings	
Clock Mode	Local Time
Date Settings	Year 2023 Month Jun Day 01
Time Settings	Hour 00 Minutes 00 Second 00

Daylight Savings Time

- **Enable Daylight Saving** – Select **Enabled** to enable Daylight Savings, and **Disabled** to disable it
- **Daylight Saving Offset** – Input the amount of time to offset daylight savings time
- **DST Start** – Input the date and time of when Daylight Saving Offset begins
- **DST End** – Input the date and time of when Daylight Savings Offset ends
- **Enable Daylight Saving** – Check the box to enable automatic daylight savings time adjustment, then adjust the fields accordingly.

Daylight Savings Time	
Enable Daylight Saving	Enabled
Daylight Saving Offset	+1:00
DST Start	Month Mar Week 2nd Day of Week Sun Hour 02
DST End	Month Nov Week 1st Day of Week Sun Hour 02

3. Click **Apply** to apply the settings and click **Save** the changes permanently to the flash by clicking the **Save** button in the top right corner.



Schedule

System > Schedules

Set up WiFi schedules with both bands with schedules.

1. Log into your access point management page (see “[Access your access point management page](#)” on page 27).
2. Click on **Schedule** under **System** from the left side menu. Please note, when clicking **Save**, the settings are saved but not applied yet.
3. Select **Enabled** to enable wireless scheduling for the access point and click **Apply** to apply the settings.

Schedule Rule Status	
Wireless Schedule	Enabled

4. Review the information below for the Schedule settings
 - **Rule Name** – Input a name for this schedule rule

- **Service** – Select the action to reboot or the wireless band for the rule to be applied to
- **Days** – Select the days for this rule to apply to
- **Start Time / End Time** – Input the start and end time for this rule

Add Schedule Rule

Rule Name	<input type="text"/>
Service	Reboot <input type="button" value="v"/>
Day(s)	Select Day(s) <input type="button" value="v"/> <input type="checkbox"/> Sun <input type="checkbox"/> Mon <input type="checkbox"/> Tue <input type="checkbox"/> Wed <input type="checkbox"/> Thur <input type="checkbox"/> Fri <input type="checkbox"/> Sat
Start Time	00 <input type="button" value="v"/> : 00 <input type="button" value="v"/>
End Time	00 <input type="button" value="v"/> : 00 <input type="button" value="v"/>

5. Click **Add** to add this rule to the schedule list.
6. Click **Apply** to apply the settings and click **Save** the changes permanently to the flash by clicking the **Save** button in the top right corner.

**LED Control**

System > LED

1. Log into your access point management page (see "[Access your access point management page](#)" on page 27).
2. Click on **LED Control** under **System** from the left side menu. Please note, when clicking **Save**, the settings are saved but not applied yet.
3. Select **On** to set the LED lights on and **Off** to set the LED lights off.

LED Control

LED

OFF ON

4. Click **Apply** to apply the settings and click **Save** the changes permanently to the flash by clicking the **Save** button in the top right corner.

**LLDP**

System > LLDP

1. Log into your access point management page (see "[Access your access point management page](#)" on page 27).
2. Click on **LLDP** under **System** from the left side menu. Please note, when clicking **Save**, the settings are saved but not applied yet.
3. Select **Enabled** to enable LLDP and **Disabled** to disable this feature.

LLDP

Status

Enabled

4. Click **Apply** to apply the settings and click **Save** the changes permanently to the flash by clicking the **Save** button in the top right corner.

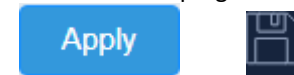
**UPnP**

System > UPnP

1. Log into your access point management page (see "[Access your access point management page](#)" on page 27).
2. Click on **UPnP** under **System** from the left side menu. Please note, when clicking **Save**, the settings are saved but not applied yet.
3. Select **Enabled** to enable UPnP and **Disabled** to disable this feature.

UPnP

Status Enabled

4. Click **Apply** to apply the settings and click **Save** the changes permanently to the flash by clicking the **Save** button in the top right corner.

Apply

Bonjour

System > Bonjour

1. Log into your access point management page (see "[Access your access point management page](#)" on page 27).
2. Click on **Bonjour** under **System** from the left side menu. Please note, when clicking **Save**, the settings are saved but not applied yet.
3. Select **Enabled** to enable Bonjour and **Disabled** to disable this feature.

Bonjour

Status Disabled

4. Click **Apply** to apply the settings and click **Save** the changes permanently to the flash by clicking the **Save** button in the top right corner.



Gateway Monitor

System > Gateway Monitor

1. Log into your access point management page (see "[Access your access point management page](#)" on page 27).
2. Click on **Gateway Monitor** under **System** from the left side menu. Please note, when clicking **Save**, the settings are saved but not applied yet.
3. Review the settings below:
 - **Status** – Select **Enabled** to enable this feature
 - **Gateway IP Address** – Input the IP address of the gateway
 - **Delay Between Timeouts** – Input the delay time between timeouts
 - **Timeout Attempts Before Reboot** – Input the timeouts between before the unit is rebooted
 - **Ping Delay After Auto Reboot** – Input the time to ping the Gateway after the unit reboots
 - **Reboot Attempts** – Input the maximum reboot attempts allowed

Wireless 2.4GHz / 5GHz Network

Wireless Network

Wireless 2.4GHz / Wireless 5GHz > Wireless Network

1. Log into your access point management page (see "[Access your access point management page](#)" on page 27).

- Click on **Wireless Network** under **Wireless 2.4GHz / Wireless GHz** from the left side menu. Please note, when clicking **Save**, the settings are saved but not applied yet.
- Review the settings below:
 - Wireless Mode** – Select the wireless mode for the selected wireless band
 - Channel Width** – Select the channel width for the selected wireless band
 - Frequency (Channel)** – Select the frequency channel for the selected wireless band
 - AP Detection** – Click the **Scan** button to scan nearby wireless Access Points

Wireless Network	
Wireless Mode	802.11 ax
Channel Width	80 MHz
Frequency (Channel)	Auto
AP Detection	<input type="button" value="Scan"/>

- Review the settings below.
 - Status** – Select **Enable** to enable this SSID or **Disabled** to disable it
 - SSID** – Displays the current SSID. SSID can be modified in the field.
 - Security Mode** – Select the Encryption method for this SSID
 - Password** – Input the password for the selected SSID
 - Edit** – Clicking on **Edit** to modify the advanced settings of the wireless SSID

Current Profiles				
Status	SSID	Security Mode	Password	Edit / Add
Enabled	TRENDnet941_5GHz_757E	WPA3-SAE Mixed AES	*****	<input type="button" value="Edit"/>

Advanced Wireless Network

- Advanced Wireless Network settings can be accessed from clicking on **Edit** from the previous step
- Review the settings and click **Apply** to Apply the settings.

- SSID** – Display & edit the SSID for this wireless network
- Status** – Select **Enabled** to enable the wireless network or **Disabled** to disable it
- Hide SSID** – Select **Enabled** to hide the SSID or **Disabled** to show the SSID
- Separate Stations** – Select **Enabled** to separate the SSID from the main network and **Disabled** to allow access

Wireless Settings	
SSID	TRENDnet941_5GHz_757E
Status	Enabled
Hide SSID	Disabled
Separate Stations	Disabled

Wireless Security

- Security Mode** – Select the encryption type for the SSID
- WPA Cipher** – Select the type of cipher for the encryption mode
- Pre-Shared Key** – Input the encryption key for the selected SSID
- Key Update Interval** – Input the key update interval in seconds

Wireless Security	
Security Mode	WPA3-Personal Mixed
WPA	
WPA Cipher	AES
Pre-Shared Key	*****
Key Update Interval	3600 Seconds

Roaming Assistant

- 802.11K Support** – Click **Enabled** to enable 802.11K roaming or **Disabled** to disable it
- Scan Period** – Select how often a scan will be done

Roaming Assistant	
802.11k Support	Disabled
Scan Period	10 Minutes

Add Schedule Rule

- **Rule Name** – Input the name of the rule
- **Day(s)** – Select the days where the SSID will be disabled
- **Start Time / End Time** – Select the time when the wireless SSID will be turned off and when the SSID will turn back on

Add Schedule Rule

Rule Name

Day(s)
 Select Day(s)
 Sun Mon Tue Wed Thur Fri Sat

Start Time :

End Time :

7. Click **Apply** to apply the settings and click **Save** the changes permanently to the flash by clicking the **Save** button in the top right corner.



Bandwidth Control

Wireless 2.4GHz / Wireless 5GHz > Wireless Bandwidth Control

This section allows the maximum download and upload throughput through the selected wireless band and wireless SSID.

1. Log into your access point management page (see "[Access your access point management page](#)" on page 27).
2. Click on **Wireless Bandwidth Control** under **Wireless 2.4GHz / Wireless 5GHz** from the left side menu. Please note, when clicking **Save**, the settings are saved but not applied yet.

3. Select **Enabled** to enable bandwidth control for the selected wireless band or **Disabled** to disable it.
4. Review the settings below:
 - **Status** – Select **Enabled** to enable bandwidth control for the selected SSID or **Disabled** to disable it
 - **SSID** – Displays the SSID
 - **Download MAX** – Input the max download throughput in (bits per second)
 - **Upload Limit** – Input the max upload throughput in (bits per second)

Wireless Bandwidth Control

Bandwidth Control

Current Profiles

Status	SSID	Download MAX	Upload Limit
<input type="text" value="Disabled"/>	TRENDnet941_5GHz_757E	<input type="text" value="10m"/> bps	<input type="text" value="1m"/> bps

5. Click **Apply** to apply the settings and click **Save** the changes permanently to the flash by clicking the **Save** button in the top right corner.



Wireless RSSI Scanner

Wireless 2.4GHz / Wireless 5GHz > Wireless RSSI Scanner

This section allows you to setup each VAP RSSI value. When STAs RSSI is less than the setting value, AP will disassociate with STA

1. Log into your access point management page (see "[Access your access point management page](#)" on page 27).
2. Click on **Wireless Bandwidth Control** under **Wireless 2.4GHz / Wireless GHz** from the left side menu. Please note, when clicking **Save**, the settings are saved but not applied yet.
3. Review the settings below and click **Apply** to apply the settings
 - **Status** – Select **Enabled** to enable RSSI scanner for the selected SSID or **Disabled** to disable it.
 - **SSID** – Displays the SSID
 - **Tolerance** – Set the action for the clients connected to the selected SSID
 - **Kick immediately** – Kick clients when it passes the RSSI threshold
 - **Detect 15, 30, 45 seconds** – Check if the client has still surpassed the RSSI threshold after the selected time frame
 - **RSSI value** – Set the RSSI threshold value

Current Profiles			
Status	SSID	Tolerance	RSSI value
Enabled	TRENDnet941_5GHz_757E	kick immediately	-90 dBm
Disabled		kick immediately	-90 dBm
Disabled		kick immediately	-90 dBm
Disabled		kick immediately	-90 dBm
Disabled		kick immediately	-90 dBm
Disabled		kick immediately	-90 dBm
Disabled		kick immediately	-90 dBm
Disabled		kick immediately	-90 dBm

4. Click **Apply** to apply the settings and click **Save** the changes permanently to the flash by clicking the **Save** button in the top right corner.



Wireless MAC Filter

Wireless 2.4GHz / Wireless 5GHz > Wireless MAC Filter

This section allows you to setup additional security filters by specifying which device wireless MAC addresses are allowed or denied access on your access point wireless network.

1. Log into your access point management page (see "[Access your access point management page](#)" on page 27).
2. Click on **Wireless MAC Filter** under **Wireless 2.4GHz / Wireless GHz** from the left side menu. Please note, when clicking **Save**, the settings are saved but not applied yet.
3. Select **Allow listed computers access and deny all others** to enable clients of specified MAC addresses wireless network access. To block clients of wireless network access, select **DENY listed computers access and allow all others**. Select **Disabled** to disable this feature.
4. Input the MAC Address of the client in the **MAC Address** field.

Wireless MAC Filter

Filter Mode	ALLOW listed computers access and deny a
MAC Address	<input style="width: 90%;" type="text"/> (Ex: 00:11:22:33:44:55)

5. Click **Apply** to apply the settings and click **Save** the changes permanently to the flash by clicking the **Save** button in the top right corner.



Wireless Advanced Settings

Wireless 2.4GHz / Wireless 5GHz > Wireless Advanced Settings

1. Log into your access point management page (see "[Access your access point management page](#)" on page 27).
2. Click on **Wireless Advanced Settings** under **Wireless 2.4GHz / Wireless GHz** from the left side menu. Please note, when clicking **Save**, the settings are saved but not applied yet.
3. Review the settings below and click **Apply** to apply the settings.
 - **Transmit Power** – Select the transmit power of the selected wireless band
 - **RTS/CTS Threshold** – Input the RTS or CTS threshold. By default it is set to 2346.
 - **Beacon Period** – Set the beacon period. By default it is set to 100
 - **DTIM** – Input the desired DTIM. By default, it is set to 1.
 - **ARP Proxy** – Select **Enabled** to enable ARP Proxy or **Disabled** to disable it
 - **Wi-Fi Multimedia (WMM)** – Select **Enabled** to enable WMM or **Disabled** to disable it. By default it is set to Disabled.

Advanced Wireless	
Transmit Power	6 dBm
RTS/CTS Threshold	2346 (range 1 - 2346, default 2346)
Beacon Period	100 ms (range 100 - 1000, default 100)
DTIM	1 (range 1 - 255, default 1)
ARP Proxy	Disabled
Wi-Fi Multimedia (WMM)	Enabled

HT Physical Mode

- **Guard Interval** – Select the Guard Interval. By default the Guard Interval is set to Auto.
- **A-MPDU** – Select **Enabled** to enable A-MPDU or **Disabled** to disable it.
 - Input the amount of Frames and select the maximum KB to support.

HT Physical Mode	
Guard Interval	Auto
A-MPDU	Enabled
255	Frames 1024 KBytes (Max)

Client Limit

- **Client Limit** – Select **Enabled** to enable the maximum number of clients that can be connected to the wireless band or **Disabled** to disable this feature
- **Max Client** – Input the maximum number of devices that can be connected to the wireless band concurrently.

Client Limit	
Client Limit	Disabled
Max Client	127

4. Click **Apply** to apply the settings and click **Save** the changes permanently to the flash by clicking the **Save** button in the top right corner.



WPS

Wireless 2.4GHz / Wireless 5GHz > WPS

This section allows you to activate WPS (Wi-Fi Protected Setup) which allows you to easily connect WPS capable wireless client devices to your access point.

1. Log into your access point management page (see "[Access your access point management page](#)" on page 27).
2. Click on **WPS** under **Wireless 2.4GHz / Wireless GHz** from the left side menu. Please note, when clicking **Save**, the settings are saved but not applied yet.

3. Select **Enabled** to enable WPS on this access point and **Disabled** to disable this feature.

WPS Config

WPS Disabled

4. Click **Apply** to apply the settings and click **Save** the changes permanently to the flash by clicking the **Save** button in the top right corner.



Management

System Management

Management > System Management

1. Log into your access point management page (see "[Access your access point management page](#)" on page 27).
2. Click on **System Management** under **Management** from the left side menu. Please note, when clicking **Save**, the settings are saved but not applied yet.
3. Input the name of the device in **Device Name**.

System Settings

Device Name TEW-941APBO

4. Click **Apply** to apply the settings and click **Save** the changes permanently to the flash by clicking the **Save** button in the top right corner.

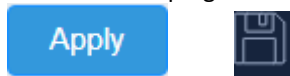

Administration

Management > System Management

1. Log into your access point management page (see "[Access your access point management page](#)" on page 27).
2. Click on **Administration** under **Management** from the left side menu. Please note, when clicking **Save**, the settings are saved but not applied yet.
3. Input the User Name, Password and the Confirm Password. Click on **Add** to add the new Username and Password.

Administrator Settings

User Name	<input type="text"/>	<small>(Maximum length is 20)</small>
Password	<input type="password"/>	<small>(Maximum length is 20)</small>
Confirm Password	<input type="password"/>	

4. From the administrator setting, the password for the user account could be modified or the account could be deleted by clicking on **Modify** or **Delete**. The default admin user account cannot be deleted.

Administration Table

Index	User Name	Password	Action
1	admin	*****	Modify
2	trendnet	*****	Modify Delete

Timeout Settings

Management > Timeout

1. Log into your access point management page (see "[Access your access point management page](#)" on page 27).

2. Click on **Timeout** under **Management** from the left side menu. Please note, when clicking **Save**, the settings are saved but not applied yet.

3. Input the time for the for the Idle timeout settings.

Timeout Settings

Web Idle Timeout (120-3600 Seconds)

4. Click **Apply** to apply the settings and click **Save** the changes permanently to the flash by clicking the **Save** button in the top right corner.

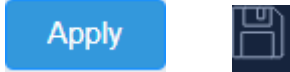

SNMP Settings

Management >SNMP Settings

1. Log into your access point management page (see "[Access your access point management page](#)" on page 27).

2. Click on **SNMP Settings** under **Management** from the left side menu. Please note, when clicking **Save**, the settings are saved but not applied yet.

3. Review the SNMP settings below

SNMP Settings

- **SNMP** – Select **Enable** to enable SNMP. *Default: Disabled*
- **Contact** – Enter the **Contact** for the SNMP in this field.
- **Location** – Enter the **Location** for the SNMP in this field.
- **Community Name (Read Only)** – Enter the community name designated with **Read Only** permissions.
- **Community Name (Read Write)** – Enter the community name designated with **Read Write** permissions.
- **Trap Destination Address** - Enter the IP address for the SNMP trap destination

- **Trap Destination Community Name** – Enter the community name for the SNMP trap destination (defined above).
- **SNMPv3** – Select **Enable** to enable SNMP v3
- **Username** – Enter the username for the SNMPv3.
- **Authorized Protocol** – Select the authorized protocol for the SNMPv3.
- **Authorized Key** – Enter the key for the protocol specified above for SNMPv3.
- **Private Protocol** – Select the private protocol for the SNMPv3.
- **Private Key** – Enter the private key for the protocol specified above for SNMPv3.
- **Engine ID** – Enter the engine ID.

SNMP Settings

SNMP	Enabled
Contact	
Location	
Community Name (Read Only)	public
Community Name (Read/Write)	private
Trap Destination Address	
Trap Destination Community Name	public
SNMPv3	Disabled
User Name	admin
Auth Protocol	None
Auth Key (8-32 Characters)	*****
Priv Protocol	None
Priv Key (8-32 Characters)	*****
Engine ID	

4. Click **Apply** to apply the settings and click **Save** the changes permanently to the flash by clicking the **Save** button in the top right corner.

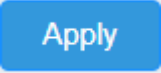

Settings Management

Management > Backup/Restore Settings

1. Log into your access point management page (see "[Access your access point management page](#)" on page 27).
2. Click on **Backup/Restore Settings** under **Management** from the left side menu. Please note, when clicking **Save**, the settings are saved but not applied yet.

Export Config Files

1. To download the config file, click **Export** to export your device's current configuration to your computer.

Export Settings

Export

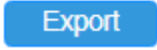

2. The file will be saved to your selected download folder.

Import Config Files

1. Click on **Choose File** to Import your config file.

Name	Date modified	Type	Size
▼ Today (1)			
TEW-941APBO_backup.tar.gz.des3	6/25/2024 12:08 PM	DES3 File	21 KB

2. Select the file will have a .des3 file extension. Click **Open** or **Upload** to use the selected file.

Reset to Factory Default / System Reboot

- To reset the unit back to factory, click **Load Default**.

- To reboot the unit, click on **Reboot**.

Reset to Factory Defaults

Load Default



System Reboot

System Reboot



Settings Management

Management > Upload Firmware

1. Log into your access point management page (see "[Access your access point management page](#)" on page 27).
2. Click on **Upload Firmware** under **Management** from the left side menu. Please note, when clicking **Save**, the settings are saved but not applied yet.
3. Select the firmware file by clicking **Choose File**. The firmware file will have an extension of .bin.

Firmware

Location

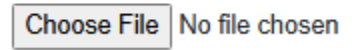

Name	Date modified	Type	Size
GUI Emulator	6/6/2024 11:58 AM	File folder	
[Release] TRENDnetTEW-941APBO_V1.0.3...	1/30/2024 12:27 PM	Adobe Acrobat D...	149 KB
Firmware Upgrade Procedure.doc	1/30/2024 12:34 PM	Microsoft Word 9...	44 KB
Firmware Upgrade Procedure.pdf	1/30/2024 12:34 PM	Adobe Acrobat D...	104 KB
FW TEW-941APBO_v1(1.0.3.06).zip	1/30/2024 12:41 PM	WinRAR ZIP archive	40,734 KB
TEW-941APBO_v1.0.3.06.bin	12/26/2023 12:03 PM	BIN File	40,629 KB
TRENDnet Firmware Release Notes.txt	1/30/2024 12:25 PM	Text Document	1 KB

4. A prompt will appear asking for confirmation of updating the firmware. Click **Apply** or **Okay** to begin the firmware update procedure.

Note Your device will automatically reboot following the firmware update.

SSH

Management > SSH

1. Log into your access point management page (see "[Access your access point management page](#)" on page 27).
2. Click on **SSH** under **Management** from the left side menu. Please note, when clicking **Save**, the settings are saved but not applied yet.
3. Select **SSH** to enable **Secure Shell Interface**. *Default: Disabled*

SSH Management

SSH Enabled

4. Click **Apply** to apply the settings and click **Save** the changes permanently to the flash by clicking the **Save** button in the top right corner.

Apply

System Log

Management > Log

1. Log into your access point management page (see "[Access your access point management page](#)" on page 27).
2. Click on **Log** under **Management** from the left side menu. Please note, when clicking **Save**, the settings are saved but not applied yet.
3. Select **Enabled** to enable system logging, or **Disabled** to disable it.
4. Input the IP Address in **Syslog Server IP Address** to where the log info should be saved.

System log

Enable System Log Enabled

Syslog Server IP Address

5. Click **Apply** to apply the settings and click **Save** the changes permanently to the flash by clicking the **Save** button in the top right corner.



Diagnostics

Management > Diagnostics

1. Log into your access point management page (see "[Access your access point management page](#)" on page 27).
2. Click on **Diagnostics** under **Management** from the left side menu. Please note, when clicking **Save**, the settings are saved but not applied yet.

Ping Test Parameter

- **IP Address** – Input the IP Address for the unit to ping
- **Packet Length** – Input the length of the packet
- **Number of Pings** – Input the number of pings to send
- **Ping** – Click **Ping** to begin the ping test

Ping Test Parameter

IP Address	<input type="text" value="192.168.10.200"/>
Packet Length	<input type="text" value="64"/>
Number of Pings	<input type="text" value="4"/>

Ping

Traceroute Parameter

- **Target** - Enter the IP address or domain name of the traceroute target and click **Traceroute** to begin.

Traceroute Parameter

Target	<input type="text" value="www.google.com"/>
--------	---

Traceroute

Speed Test Parameter

- **Target IP / Domain Name** – Enter the IP address or domain name of the endpoint of the speed test.
- **Time Period** – Specify the duration of the speed test.
- **Check Interval** – Specify the interval between connectivity checks.
- **IPv4 Port** – Enter the IPv4 Port for the destination endpoint of the speed test.
- **IPv6 Port** – Enter the IPv6 Port for the destination endpoint of the speed test.

- Press **Speed** to begin the test.

Speed Test Parameter

Target IP / Domain Name	<input type="text"/>
Time Period	<input type="text" value="10"/> Sec
Check Interval	<input type="text" value="1"/> Sec
IPv4 Port	5201
IPv6 Port	60001

Speed

Technical Specifications

Standards

- IEEE 802.3
- IEEE 802.3u
- IEEE 802.3x
- IEEE 802.3ab
- IEEE 802.3at
- IEEE 802.3bz
- IEEE 802.1Q
- IEEE 802.11a
- IEEE 802.11b
- IEEE 802.11g
- IEEE 802.11n (5GHz: up to 300Mbps, 2.4GHz: up to 300Mbps)*
- IEEE 802.11r*
- IEEE 802.11v
- IEEE 802.11ac (5GHz: up to 867Mbps)*
- IEEE 802.11ax (5GHz: up to 1201Mbps, 2.4GHz: up to 573Mbps)*

Hardware Interface

- 1 x PoE+ 2.5G LAN port (power input)
- 4 x RP-SMA (female) antenna connectors
- LED indicators

Features

- 802.11ax WiFi 6 support
- IP67 rated housing
- MU-MIMO
- Airtime fairness
- Band steering
- 802.1Q VLAN assignment per SSID
- IPv6 support
- LEDs on/off

- 802.11k intelligent radio resource management
- RSSI Threshold (client signal strength and connectivity control)
- LLDP
- Bonjour/UPnP

Operation Modes

- Access Point
- Client Bridge
- Repeater

Management/Monitoring

- Web based management (HTTP/HTTPS)
- Command Line Interface (SSH)
- SNMP v2c/v3
- Spanning Tree Protocol (STP)
- Event logging
- Ping test
- Traceroute
- Performance throughput test
- Schedule WiFi radio enable/disable
- Ping watchdog/gateway connection monitor
- Reboot & scheduled automatic reboot
- Channel utilization scan/AP detection

Hive Cloud Management

- Configure, monitor, and manage through the TRENDnet Hive Cloud Management Portal remotely via PC or Mac web browser, or through the mobile app
- Multi-device management
- Provisioning through scheduled batch firmware or configuration updates for multiple switches
- Event/hardware network monitoring (CPU/memory utilization)

- Configure features such as IP address settings, WiFi settings, operation modes, and LED control through cloud management

Access Control

- Wireless encryption: OWE (Opportunistic Wireless Encryption), WPA/WPA2/WPA3-RADIUS (Enterprise), WPA-PSK/WPA2-PSK/WPA3-SAE (Personal)
- MAC filter (max. entries: 32)
- Maximum client limit
- Client isolation/separate stations

QoS

- WMM
- Bandwidth control per SSID

SSID

- Up to 8 SSIDs per wireless band (16 total)

Frequency

- 2.4GHz: 2.412 – 2.472GHz
- 5GHz: 5.180 – 5.825GHz

Wireless Channels

- 2.4GHz: 1–11
- 5GHz: 36, 40, 44, 48, 149, 153, 157, 161 and 165

Modulation

- DBPSK/DQPSK/CCK for DSSS technique
- BPSK/QPSK/16-QAM/64-QAM/256-QAM/1024-QAM for OFDM/OFDMA

Antenna Gain

- 2.4GHz: 2 x 5 dBi external
- 5GHz: 2 x 5 dBi external

Antenna Pattern

- 2.4GHz H-Plane

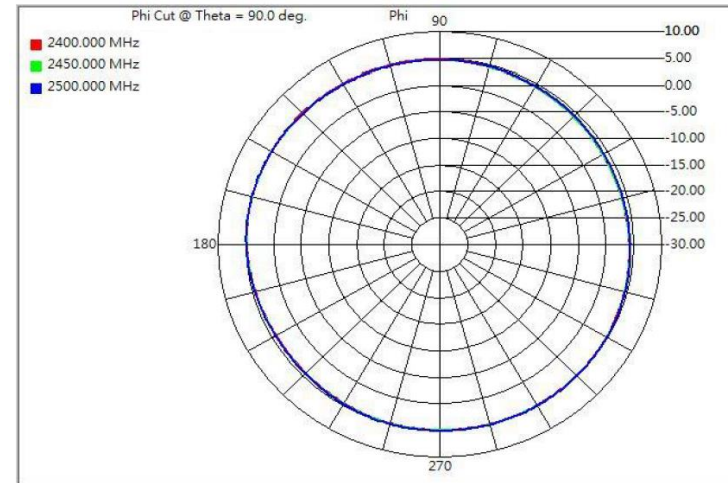

- 2.4GHz E-Plane

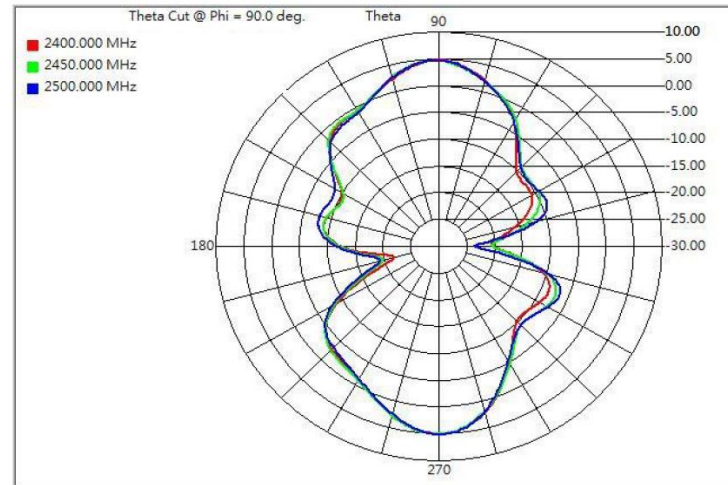

• 5GHz H-Plane

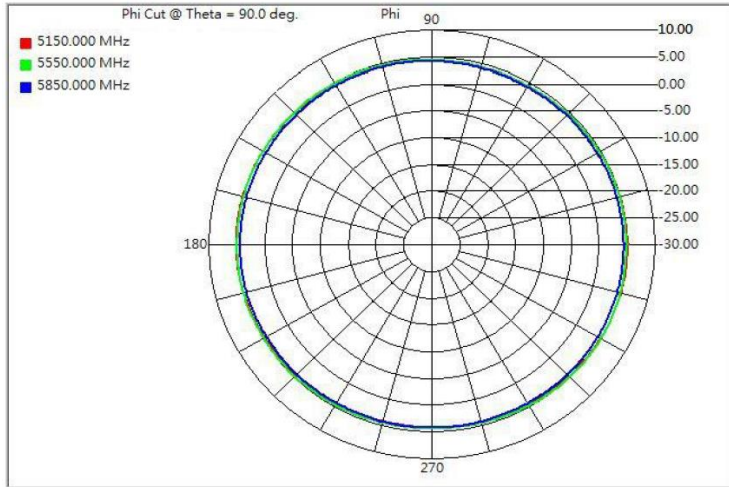

• 5GHz E-Plane

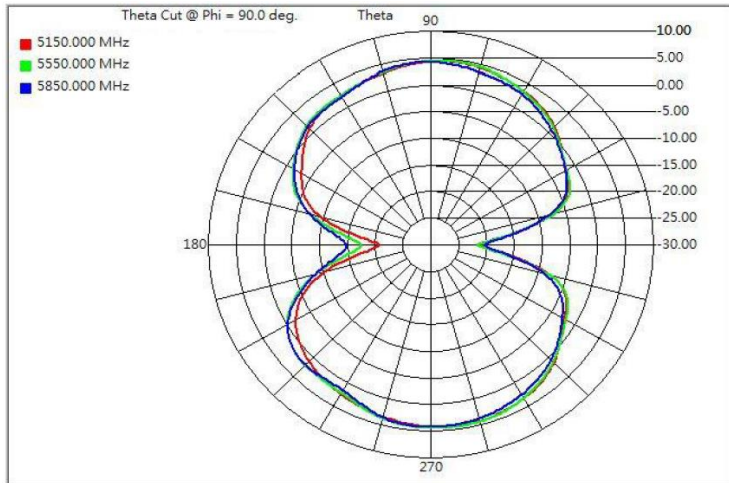

Wireless Output Power

- 802.11a: 21 dBm (max.)

- 802.11b: 19 dBm (max.)
- 802.11g: 19 dBm (max.)
- 802.11n (2.4GHz): 19 dBm (max.)
- 802.11n (5GHz): 21 dBm (max.)
- 802.11ac: 21 dBm (max.)
- 802.11ax (2.4GHz): 19 dBm (max.)
- 802.11ax (5GHz): 21 dBm (max.)

Receiving Sensitivity

- 802.11a: -73 dBm (typical) @ 54 Mbps
- 802.11b: -88 dBm (typical) @ 11 Mbps
- 802.11g: -74 dBm (typical) @ 54 Mbps
- 802.11n (2.4GHz): -74 dBm (typical) @ 300 Mbps
- 802.11n (5GHz): -72 dBm (typical) @ 300 Mbps
- 802.11ac: -58 dBm (typical) @ 867 Mbps
- 802.11ax (2.4GHz): -59 dBm (typical) @ 573 Mbps
- 802.11ax (5GHz): -53 dBm (typical) @ 1201 Mbps

Power

- IEEE 802.3at Type 2 PoE+ PD Class 4
- Max. consumption: 25W

Operating Temperature

- -22° – 60° C (-7.6° – 140° F)

Operating Humidity

- Max. 90% non-condensing

Certifications

- FCC

Dimensions

- 122 x 205 x 45mm (4.8 x 8.07 x 1.77 in.)

Weight

- 706g (24.9 oz.)

Warranty:

- 3 year

Package Contents

- TEW-941APBO
- 2 x Detachable 2.4GHz 5 dBi antennas
- 2 x Detachable 5GHz 5 dBi antennas
- IP67 weather rated cable gland
- Mounting hardware
- Quick Installation Guide

Disclaimer

*Maximum wireless signal rates are referenced from IEEE 802.11 theoretical specifications. Actual data throughput and coverage will vary depending on interference, network traffic, building materials and other conditions. For maximum performance of up to 1101Mbps use with an 1101Mbps 802.11ax wireless adapter. For maximum performance of up to 600Mbps, use with a 600Mbps 802.11n wireless adapter. Multi-User MIMO (MU-MIMO) requires the use of multiple MU-MIMO enabled wireless adapters.

Appendix

How to find your IP address?

Note: Please note that although the following procedures provided to follow for your operating system on configuring your network settings can be used as general guidelines, however, it is strongly recommended that you consult your computer or operating system manufacturer directly for assistance on the proper procedure for configuring network settings.

Command Prompt Method

Windows 2000/XP/Vista/7/8.1/10/11

1. On your keyboard, press **Windows Logo+R** keys simultaneously to bring up the Run dialog box.
2. In the dialog box, type **cmd** to bring up the command prompt.
3. In the command prompt, type **ipconfig /all** to display your IP address settings.

MAC OS X

1. Navigate to your **Applications** folder and open **Utilities**.
2. Double-click on **Terminal** to launch the command prompt.
3. In the command prompt, type **ipconfig getifaddr <en0 or en1>** to display the wired or wireless IP address settings.

Note: **en0** is typically the wired Ethernet and **en1** is typically the wireless Airport interface.

Graphical Method

MAC OS 10.6/10.5

1. From the Apple menu, select **System Preferences**.
2. In System Preferences, from the **View** menu, select **Network**.
3. In the Network preference window, click a network port (e.g., Ethernet, AirPort, modem). If you are connected, you'll see your IP address settings under "Status:"

MAC OS 10.4

1. From the Apple menu, select **Location**, and then **Network Preferences**.
2. In the Network Preference window, next to "Show:", select **Network Status**. You'll see your network status and your IP address settings displayed.

Note: If you are experiencing difficulties, please contact your computer or operating system manufacturer for assistance.

How to configure your network settings to obtain an IP address automatically or use DHCP?

Note: Please note that although the following procedures provided to follow for your operating system on configuring your network settings can be used as general guidelines, however, it is strongly recommended that you consult your computer or operating system manufacturer directly for assistance on the proper procedure for configuring network settings.

Windows 7/8.1/10/11

- a. Go into the **Control Panel**, click **Network and Sharing Center**.
- b. Click **Change Adapter Settings**, right-click the **Local Area Connection** icon.
- c. Then click **Properties** and click **Internet Protocol Version 4 (TCP/IPv4)**.
- d. Then click **Obtain an IP address automatically** and click **OK**.

Windows Vista

- a. Go into the **Control Panel**, click **Network and Internet**.
- b. Click **Manage Network Connections**, right-click the **Local Area Connection** icon and click **Properties**.
- c. Click **Internet Protocol Version (TCP/IPv4)** and then click **Properties**.
- d. Then click **Obtain an IP address automatically** and click **OK**.

Windows XP/2000

- a. Go into the **Control Panel**, double-click the **Network Connections** icon
- b. Right-click the **Local Area Connection** icon and the click **Properties**.
- c. Click **Internet Protocol (TCP/IP)** and click **Properties**.
- d. Then click **Obtain an IP address automatically** and click **OK**.

MAC OS 10.4/10.5/10.6

- a. From the **Apple**, drop-down list, select **System Preferences**.
- b. Click the **Network** icon.
- c. From the **Location** drop-down list, select **Automatic**.
- d. Select and view your Ethernet connection.
 - In MAC OS 10.4, from the **Show** drop-down list, select **Built-in Ethernet** and select the **TCP/IP** tab.
 - In MAC OS 10.5/10.6, in the left column, select **Ethernet**.
- e. Configure TCP/IP to use DHCP.

In MAC 10.4, from the **Configure IPv4**, drop-down list, select **Using DHCP** and click the **Apply Now** button.

In MAC 10.5, from the **Configure** drop-down list, select **Using DHCP** and click the **Apply** button.

In MAC 10.6, from the **Configure** drop-down list, select **Using DHCP** and click the **Apply** button.

f. Restart your computer.

Note: *If you are experiencing difficulties, please contact your computer or operating system manufacturer for assistance.*

How to configure your network settings to use a static IP address?

Note: *Please note that although the following procedures provided to follow for your operating system on configuring your network settings can be used as general guidelines, however, it is strongly recommended that you consult your computer or operating system manufacturer directly for assistance on the proper procedure for configuring network settings.*

Windows 7/8.1/10/11

- a. Go into the **Control Panel**, click **Network and Sharing Center**.
- b. Click **Change Adapter Settings**, right-click the **Local Area Connection** icon.
- c. Then click **Properties** and click **Internet Protocol Version 4 (TCP/IPv4)**.
- d. Then click **Use the following IP address**, and assign your network adapter a static IP address. Click **OK**

Windows Vista

- a. Go into the **Control Panel**, click **Network and Internet**.
- b. Click **Manage Network Connections**, right-click the **Local Area Connection** icon and click **Properties**.
- c. Click **Internet Protocol Version (TCP/IPv4)** and then click **Properties**.
- d. Then click **Use the following IP address**, and assign your network adapter a static IP address. Click **OK**

Windows XP/2000

- a. Go into the **Control Panel**, double-click the **Network Connections** icon
- b. Right-click the **Local Area Connection** icon and the click **Properties**.
- c. Click **Internet Protocol (TCP/IP)** and click **Properties**.

d. Then click **Use the following IP address**, and assign your network adapter a static IP address. Click **OK**

MAC OS 10.4/10.5/10.6

- a. From the **Apple**, drop-down list, select **System Preferences**.
- b. Click the **Network** icon.
- c. From the **Location** drop-down list, select **Automatic**.
- d. Select and view your Ethernet connection.

How to find your MAC address?

In Windows 2000/XP/Vista/7/8,

Your computer MAC addresses are also displayed in this window, however, you can type **getmac -v** to display the MAC addresses only.

In MAC OS 10.4,

1. **Apple Menu > System Preferences > Network**
2. From the **Show** menu, select **Built-in Ethernet**.
3. On the **Ethernet** tab, the **Ethernet ID** is your MAC Address.

In MAC OS 10.5/10.6,

1. **Apple Menu > System Preferences > Network**
2. Select **Ethernet** from the list on the left.
3. Click the **Advanced** button.
3. On the **Ethernet** tab, the **Ethernet ID** is your MAC Address.

How do I use the ping tool to check for network device connectivity?**Windows 2000/XP/Vista/7/8.1/10**

1. On your keyboard, press **Windows Logo+R** keys simultaneously to bring up the Run dialog box.
2. In the dialog box, type **cmd** to bring up the command prompt.
3. In the command prompt, type **ping <ip_address>** with the **<ip_address>** being the IP address you want ping and check for connectivity.

Example: Usage of ping command and successful replies from device.

```
C:\Users>ping 192.168.10.100
```

```
Pinging 192.168.10.100 with 32 bytes of data:
```

```
Reply from 192.168.10.100: bytes=32 time<1ms TTL=64
```

```
Reply from 192.168.10.100: bytes=32 time<1ms TTL=64
```

```
Reply from 192.168.10.100: bytes=32 time<1ms TTL=64
```

```
Reply from 192.168.10.100: bytes=32 time<1ms TTL=64
```

Ping statistics for 192.168.10.100:

```
Packets: Sent = 4, Received = 4, Lost = 0 (0% loss),
```

Approximate round trip times in milli-seconds:

```
Minimum = 0ms, Maximum = 0ms, Average = 0ms
```

MAC OS X



1. Navigate to your **Applications** folder and open **Utilities**.
2. Double-click on **Terminal** to launch the command prompt.
3. In the command prompt, type **ping -c <#> <ip_address>** with the **<#>** ping being the number of time you want to ping and the **<ip_address>** being the IP address you want ping and check for connectivity.

Example: ping -c 4 192.168.10.100

How to connect to a wireless network using the built-in Windows utility?

Note: Please note that although the following procedures provided to follow for your operating system on configuring your network settings can be used as general guidelines, however, it is strongly recommended that you consult your computer or operating system manufacturer directly for assistance on the proper procedure for connecting to a wireless network using the built-in utility.

Windows 7/8.1/10/11

1. Open Connect to a Network by clicking the network icon ( or ) in the notification area.
2. In the list of available wireless networks, click the wireless network you would like to connect to, then click **Connect**.
4. You may be prompted to enter a security key in order to connect to the network.
5. Enter in the security key corresponding to the wireless network, and click **OK**.

Windows Vista

1. Open Connect to a Network by clicking the **Start Button**  and then click **Connect To**.
2. In the **Show** list, click **Wireless**.
3. In the list of available wireless networks, click the wireless network you would like to connect to, then click **Connect**.
4. You may be prompted to enter a security key in order to connect to the network.
5. Enter in the security key corresponding to the wireless network, and click **OK**.

Windows XP

1. Right-click the network icon in the notification area, then click **View Available Wireless Networks**.
2. In **Connect to a Network**, under **Available Networks**, click the wireless network you would like to connect to.
3. You may be prompted to enter a security key in order to connect to the network.
4. Enter in the security key corresponding to the wireless network, and click **Connect**.

Federal Communication Commission Interference Statement

This device complies with Part 15 of the FCC Rules. Operation is subject to the following two conditions: (1) This device may not cause harmful interference, and (2) this device must accept any interference received, including interference that may cause undesired operation.

This equipment has been tested and found to comply with the limits for a Class B digital device, pursuant to Part 15 of the FCC Rules. These limits are designed to provide reasonable protection against harmful interference in a residential installation. This equipment generates, uses and can radiate radio frequency energy and, if not installed and used in accordance with the instructions, may cause harmful interference to radio communications. However, there is no guarantee that interference will not occur in a particular installation. If this equipment does cause harmful interference to radio or television reception, which can be determined by turning the equipment off and on, the user is encouraged to try to correct the interference by one of the following measures:

- Reorient or relocate the receiving antenna.
- Increase the separation between the equipment and receiver.
- Connect the equipment into an outlet on a circuit different from that to which the receiver is connected.
- Consult the dealer or an experienced radio/TV technician for help.

FCC Caution: Any changes or modifications not expressly approved by the party responsible for compliance could void the user's authority to operate this equipment.

This transmitter must not be co-located or operating in conjunction with any other antenna or transmitter.



IMPORTANT NOTE: Radiation Exposure Statement:

This equipment complies with FCC radiation exposure limits set forth for an uncontrolled environment. This equipment should be installed and operated with minimum distance 20cm between the radiator & your body.

This radio transmitter FCC ID: XU8TEW941APBO has been approved by FCC to operate with antenna types listed below with maximum permissible gain and required antenna impedance for each antenna type indicated. Antenna types not included in the list, having a gain greater than the maximum gain indicated for that type, are strictly prohibited for use with this device.

No.	Manufacturer	Part No.	Antenna Type	Peak Gain
1	Master Wave	98143MRSX000	Dipole	5.17dBi
2	Master Wave	98143URSX000	Dipole	5.17dBi

Industry Canada Statement

This device complies with ISED's licence-exempt RSSs. Operation is subject to the following two conditions: (1) This device may not cause harmful interference, and (2) this device must accept any interference received, including interference that may cause undesired operation.

Le présent appareil est conforme aux CNR d'ISED applicables aux appareils radio exempts de licence. L'exploitation est autorisée aux deux conditions suivantes : (1) le dispositif ne doit pas produire de brouillage préjudiciable, et (2) ce dispositif doit accepter tout brouillage reçu, y compris un brouillage susceptible de provoquer un fonctionnement indésirable.

Caution :

(i) the device for operation in the band 5150-5250 MHz is only for indoor use to reduce the potential for harmful interference to co-channel mobile satellite systems;

(ii) for devices with detachable antenna(s), the maximum antenna gain permitted for devices in the band 5725-5850 MHz shall be such that the equipment still complies with the e.i.r.p. limits as appropriate;

(iii) where applicable, antenna type(s), antenna models(s), and worst-case tilt angle(s) necessary to remain compliant with the e.i.r.p. elevation mask requirement set forth in section 6.2.2.3 shall be clearly indicated.

Avertissement:

(i) les dispositifs fonctionnant dans la bande 5150-5250 MHz sont réservés uniquement pour une utilisation à l'intérieur afin de réduire les risques de brouillage préjudiciable aux systèmes de satellites mobiles utilisant les mêmes canaux;

(ii) pour les dispositifs munis d'antennes amovibles, le gain maximal d'antenne permis (pour les dispositifs utilisant la bande de 5 725 à 5 850 MHz) doit être conforme à la limite de la p.i.r.e. spécifiée, selon le cas;

(iii) lorsqu'il y a lieu, les types d'antennes (s'il y en a plusieurs), les numéros de modèle de l'antenne et les pires angles d'inclinaison nécessaires pour rester conforme à l'exigence de la p.i.r.e. applicable au masque d'élévation, énoncée à la section 6.2.2.3, doivent être clairement indiqués.

Radiation Exposure Statement:

This equipment complies with ISED radiation exposure limits set forth for an uncontrolled environment. This equipment should be installed and operated with greater than 20cm between the radiator & your body.

Déclaration d'exposition aux radiations:

Cet équipement est conforme aux limites d'exposition aux rayonnements ISED établies pour un environnement non contrôlé. Cet équipement doit être installé et utilisé à plus de 20cm entre le radiateur et votre corps.

Approved antenna list

No.	Manufacturer	Part No.	Antenna Type	Peak Gain
1	Master Wave	98143MRSX000	Dipole	5.17dBi
2	Master Wave	98143URSX000	Dipole	5.17dBi

Professional installation instruction

1. Installation personal

This product is designed for specific application and needs to be installed by a qualified personal who has RF and related rule knowledge. The general user shall not attempt to install or change the setting.

2. Installation location

The product shall be installed at a location where the radiating antenna can be kept 20cm from nearby person in normal operation condition to meet regulatory RF exposure requirement.

3. External antenna

Use only the antennas which have been approved by the applicant. The non-approved antenna(s) may produce unwanted spurious or excessive RF transmitting power which may lead to the violation of FCC/IC limit and is prohibited.

4. Installation procedure

Please refer to user's manual for the detail.

5. Warning

Please carefully select the installation position and make sure that the final output power does not exceed the limit set force in relevant rules. The violation of the rule could lead to serious federal penalty.

Limited Warranty

TRENDnet warrants only to the original purchaser of this product from a TRENDnet authorized reseller or distributor that this product will be free from defects in material and workmanship under normal use and service. This limited warranty is non-transferable and does not apply to any purchaser who bought the product from a reseller or distributor not authorized by TRENDnet, including but not limited to purchases from Internet auction sites.

Limited Warranty

TRENDnet warrants its products against defects in material and workmanship, under normal use and service. Specific warranty periods are listed on each of the respective product pages on the TRENDnet website.

- AC/DC Power Adapter, Cooling Fan, and Power Supply carry a one-year warranty.

Limited Lifetime Warranty

TRENDnet offers a limited lifetime warranty for all of its metal-enclosed network switches that have been purchased in the United States/Canada on or after 1/1/2015.

- Cooling fan and internal power supply carry a one-year warranty

To obtain an RMA, the ORIGINAL PURCHASER must show Proof of Purchase and return the unit to the address provided. The customer is responsible for any shipping-related costs that may occur. Replacement goods will be shipped back to the customer at TRENDnet's expense.

Upon receiving the RMA unit, TRENDnet may repair the unit using refurbished parts. In the event that the RMA unit needs to be replaced, TRENDnet may replace it with a refurbished product of the same or comparable model.

In the event that, after evaluation, TRENDnet cannot replace the defective product or there is no comparable model available, we will refund the depreciated value of the product.

If a product does not operate as warranted during the applicable warranty period, TRENDnet shall reserve the right, at its expense, to repair or replace the defective product or part and deliver an equivalent product or part to the customer. The repair/replacement unit's warranty continues from the original date of purchase. All products that are replaced become the property of TRENDnet. Replacement products may be new or reconditioned. TRENDnet does not issue refunds or credit. Please contact the point-of-purchase for their return policies.

TRENDnet shall not be responsible for any software, firmware, information, or memory data of customer contained in, stored on, or integrated with any products returned to TRENDnet pursuant to any warranty.

There are no user serviceable parts inside the product. Do not remove or attempt to service the product by any unauthorized service center. This warranty is voided if (i) the product has been modified or repaired by any unauthorized service center, (ii) the product was subject to accident, abuse, or improper use, or (iii) the product was subject to conditions more severe than those specified in the manual.

Warranty service may be obtained by contacting TRENDnet within the applicable warranty period and providing a copy of the dated proof of the purchase. Upon proper submission of required documentation, a Return Material Authorization (RMA) number will be issued. An RMA number is required in order to initiate warranty service support for all TRENDnet products. Products that are sent to TRENDnet for RMA service must have the RMA number marked on the outside of return packages and sent to TRENDnet prepaid, insured and packaged appropriately for safe shipment. International customers

shipping from outside of the USA and Canada are responsible for any return shipping and/or customs charges, including but not limited to, duty, tax, and other fees.

Refurbished product: Refurbished products carry a 90-day warranty after date of purchase. Please retain the dated sales receipt with purchase price clearly visible as evidence of the original purchaser's date of purchase. Replacement products may be refurbished or contain refurbished materials. If TRENDnet, by its sole determination, is unable to replace the defective product, we will offer a refund for the depreciated value of the product.

WARRANTIES EXCLUSIVE: IF THE TRENDNET PRODUCT DOES NOT OPERATE AS WARRANTED ABOVE, THE CUSTOMER'S SOLE REMEDY SHALL BE, AT TRENDNET'S OPTION, REPAIR OR REPLACE. THE FOREGOING WARRANTIES AND REMEDIES ARE EXCLUSIVE AND ARE IN LIEU OF ALL OTHER WARRANTIES, EXPRESSED OR IMPLIED, EITHER IN FACT OR BY OPERATION OF LAW, STATUTORY OR OTHERWISE, INCLUDING WARRANTIES OF MERCHANTABILITY AND FITNESS FOR A PARTICULAR PURPOSE. TRENDNET NEITHER ASSUMES NOR AUTHORIZES ANY OTHER PERSON TO ASSUME FOR IT ANY OTHER LIABILITY IN CONNECTION WITH THE SALE, INSTALLATION, MAINTENANCE, OR USE OF TRENDNET'S PRODUCTS.

TRENDNET SHALL NOT BE LIABLE UNDER THIS WARRANTY IF ITS TESTING AND EXAMINATION DISCLOSE THAT THE ALLEGED DEFECT IN THE PRODUCT DOES NOT EXIST OR WAS CAUSED BY CUSTOMER'S OR ANY THIRD PERSON'S MISUSE, NEGLIGENCE, IMPROPER INSTALLATION OR TESTING, UNAUTHORIZED ATTEMPTS TO REPAIR OR MODIFY, OR ANY OTHER CAUSE BEYOND THE RANGE OF THE INTENDED USE, OR BY ACCIDENT, FIRE, LIGHTNING, OR OTHER HAZARD.

LIMITATION OF LIABILITY: TO THE FULL EXTENT ALLOWED BY LAW, TRENDNET ALSO EXCLUDES FOR ITSELF AND ITS SUPPLIERS ANY LIABILITY, WHETHER BASED IN

CONTRACT OR TORT (INCLUDING NEGLIGENCE), FOR INCIDENTAL, CONSEQUENTIAL, INDIRECT, SPECIAL, OR PUNITIVE DAMAGES OF ANY KIND, OR FOR LOSS OF REVENUE OR PROFITS, LOSS OF BUSINESS, LOSS OF INFORMATION OR DATE, OR OTHER FINANCIAL LOSS ARISING OUT OF OR IN CONNECTION WITH THE SALE, INSTALLATION, MAINTENANCE, USE, PERFORMANCE, FAILURE, OR INTERRUPTION OF THE POSSIBILITY OF SUCH DAMAGES, AND LIMITS ITS LIABILITY TO REPAIR, REPLACEMENT, OR REFUND OF THE PURCHASE PRICE PAID, AT TRENDNET'S OPTION. THIS DISCLAIMER OF LIABILITY FOR DAMAGES WILL NOT BE AFFECTED IF ANY REMEDY PROVIDED HEREIN SHALL FAIL OF ITS ESSENTIAL PURPOSE.

Governing Law: This Limited Warranty shall be governed by the laws of the state of California.

Some TRENDnet products include software code written by third party developers. These codes are subject to the GNU General Public License ("GPL") or GNU Lesser General Public License ("LGPL").

Visit <http://www.trendnet.com/gpl> or the support section on <http://www.trendnet.com> and search for the desired TRENDnet product to access to the GPL Code or LGPL Code. These codes are distributed WITHOUT WARRANTY and are subject to the copyrights of the developers. TRENDnet does not provide technical support for these codes. Please visit <http://www.gnu.org/licenses/gpl.txt> or <http://www.gnu.org/licenses/lgpl.txt> for specific terms of each license.

PWP07172015v3

2019/09/16



Product Warranty Registration

Please take a moment to register your product online.
Go to TRENDnet's website at <http://www.trendnet.com/register>

TRENDnet
20675 Manhattan Place
Torrance, CA 90501. USA