

TRENDNET[®]



Quick Installation Guide

TFC-1600(V1)

Table of Contents

1 Português

1. Antes de Começar
2. Instalação do hardware

1. Antes de Começar

Conteúdo da Embalagem





- Conversor Fibra Media
- Guia de instalação rápida
- Cabo de alimentação
- Suportes de montagem

Requisitos do ambiente

- Ambiente bastante fresco e seco
- Ambiente livre de fortes geradores de campo eletromagnético (como motores), vibração, poeira e exposição direta à luz solar
- Switch 10/100Mbps Ethernet
- Cabo de fibra monomodo
- Cabo Ethernet RJ-45 CAT-5
- Chassi TFC-1600 (opcional) ou superfície nivelada e resistente que suporta o peso do conversor de fibra
- TFC-1600MM (opcional)

Nota: O recurso de gerenciamento requer o chassi TFC-1600 e o módulo de gerenciamento TFC-1600MM.

Modelos compatíveis

Nome do modelo	Multimodo / Monomodo	Conector de fibra
TFC-110S60i / TFC-110S60 / TFC-110S30i / TFC-110S30 / TFC-110S15i / TFC-110S15 / TFC-110S100 / TFC-1000S70 / TFC-1000S50 / TFC-1000S20	Monomodo (Duplex)	SC (Duplex) 
TFC-110S40D5i / TFC-110S40D3i / TFC-110S40D3 / TFC-110S20D5i / TFC-110S20D5 / TFC-110S20D3i / TFC-110S20D3 / TFC-1000S60D5 / TFC-1000S60D3 / TFC-1000S40D5 / TFC-1000S40D3 / TFC-1000S10D5 / TFC-1000S10D3	Monomodo (Simple)	SC (Simple) 
TFC-110MST (ST) / TFC-110MM (MT-RJ)	Multimodo	ST (Duplex) 
TFC-110MSC / TFC-1000MSC	Multimodo	MT-RJ (Simple) 
TFC-1000MGA	Multimodo / Monomodo	Depende no SFP

2. Instalação do Hardware

Instalação de dois conversores de fibra autônomos

1. Conecte o cabo de fibra aos conversores de fibra. Este cabo deve ser de monomodo.
2. Conecte um cabo Ethernet RJ-45 da porta Ethernet nos conversores de fibra à uma porta Ethernet no seu switch (por exemplo, TEG-160WS).
3. Conecte o adaptador de energia na parte traseira do conversor de fibra.

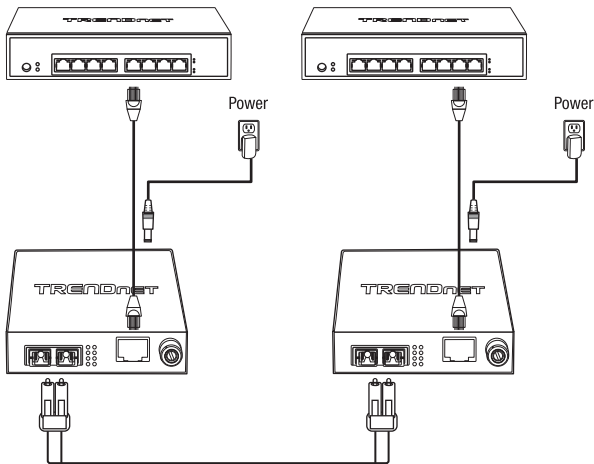

Nota: Os cabos TX e RX devem estar invertidos na conexão de fibra oposta.

Instalando o fontes de alimentação

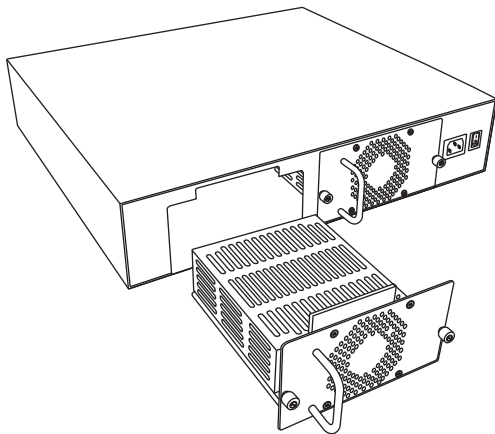

Nota: Fonte de alimentação redundante opcional (TFC-1600RP) vendida separadamente.

Instalando o Conversor de Fibra em um Chassi

1. Desaparafuse a tampa do compartimento desejado no chassi.

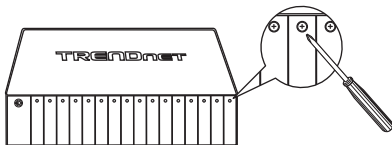

2. Desaperte o parafuso e remova o conversor de fibra da caixa de metal.

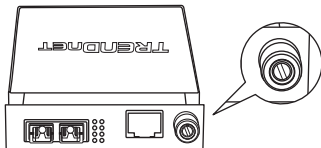

3. Deslize o conversor de mídia em um slot disponível e aperte o parafuso.

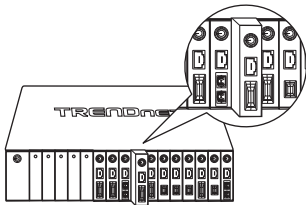

A instalação agora está completa.

Certifications

This device complies with Part 15 of the FCC Rules. Operation is subject to the following two conditions:
(1) this device may not cause harmful interference, and
(2) this device must accept any interference received.
Including interference that may cause undesired operation.



Waste electrical and electronic products must not be disposed of with household waste. Please recycle where facilities exist. Check with your Local Authority or Retailer for recycling advice.

- This equipment has been tested and found to comply with the limits for a Class A digital device, pursuant to part 15 of the FCC Rules. These limits are designed to provide reasonable protection against harmful interference when the equipment is operated in a commercial environment. This equipment generates, uses, and can radiate radio frequency energy and, if not installed and used in accordance with the instruction manual, may cause harmful interference to radio communications. Operation of this equipment in a residential area is likely to cause harmful interference in which case the user will be required to correct the interference at his own expense.
- FCC Caution: Any changes or modification not expressly approved by the party responsible for compliance could void the user's authority to operate this equipment.

Technical Support

If you have any questions regarding the product installation, please contact our Technical Support.
Toll free US/Canada: **1-866-845-3673**
Regional phone numbers available at www.trendnet.com/support

TRENDnet

20675 Manhattan Place
Torrance, CA 90501
USA

Power supply connected caution

The equipment power supply cord shall be connected to a socket-outlet with earthing connection.

Advertencia

Le cordon d'alimentation de l'appareil doit être raccordé à une prise de courant avec mise à la terre.

Note

The Manufacturer is not responsible for any radio or TV interference caused by unauthorized modifications to this equipment. Such modifications could void the user's authority to operate the equipment.

Advertencia

En todos nuestros equipos se mencionan claramente las características del adaptador de alimentación necesario para su funcionamiento. El uso de un adaptador distinto al mencionado puede producir daños físicos y/o daños al equipo conectado. El adaptador de alimentación debe operar con voltaje y frecuencia de la energía eléctrica domiciliar existente en el país o zona de instalación.

Product Warranty Registration

Please take a moment to register your product online. Go to TRENDnet's website at: www.trendnet.com/register