

TRC
Certificate of Compliance

Training Research Co., Ltd.

hereby certifies that

EMC TEST Class A

**8-Port Gigabit Ethernet Switch
Model No.: TEG-S80TXE**

Made by

TRENDWare International Inc.

3135 Kashiwa Street Torrance, CA 90505, U.S.A.

is fulfilled

**EMI: EN 55022:1998, EN61000-3-2: 2000, EN61000-3-3: 1995+A1: 2001
EMS: EN 55024:1998→ EN 61000-4-2/1995, EN 61000-4-3/1996, EN 61000-4-4/1995
EN 61000-4-5/1995, EN 61000-4-6/1996, EN 61000-4-8/1993, EN 61000-4-11/1994**

Test Date: November 4, 2003

Verification Registration No.: C51CE257

November 27, 2003

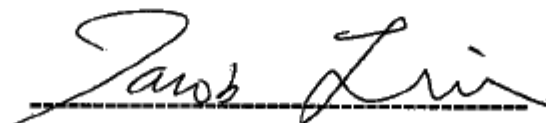

V. General Manager, Jacob Lin

CE CE CE CE CE

Training Research Co., Ltd. (NVLAP LAB CODE: 200174-0)

Report No.	C51CE257	
Directives Standard	89/336/EEC EMC, Class A EN 50022/EN 55024 (CE), ICES-003 (Canada)	
Applicant Applicant address	TRENDWare International Inc. 3135 Kashiwa Street Torrance, CA 90505, U.S.A.	
Items tested	8-Port Gigabit Ethernet Switch	
Model No.	TEG-S80TXE	
Sample No.	C513275	
Results	Compliance (As detailed within this report)	
Date	10/22/2003 (month / day / year)(Sample received) 11/04/2003 (month / day / year)(Tested)	
Prepared by		Project Engineer
Authorized by		V. General Manager (Jacob Lin)
Issue date	November 27, 2003	(month / day / year)
Modifications	None	
Tested by	Training Research Co., Ltd. (Accredited by NVLAP)	
Office at	1F, No. 255, Nan Yang Street, Hsichih, Taipei Hsien 221, Taiwan	
Open site at	No. 15, Lane 530, Pa-Lian RD., Sec. 1, Hsichih City, Taipei Hsien, Taiwan, R.O.C..	

Conditions of issue :

- *This test report shall not be reproduced except in full, without written approval of TRC. And the test result contained within this report only relate to the sample submitted for testing.*
- *The test data in this test report are following the procedures in accordance with the terms of accreditation.*
- *This test report and measurements made by TRC are traceable to the NIST only Conducted and Radiated Method (TRC is accredited by NVLAP, code No.: 200174-0).*
- *The device has been tested is fully complied with the requirements the Directive 89/336/EEC (CE), AS/NZS CISPR 22: 2002 (C-Tick) and ICES-003 (Canada).*

Contents

Chapter 0 Emission and Susceptibility Standards	3
Chapter 1 Introduction	
Description of EUT	4
Configuration of Test Setup	5
List of Support Equipment	6
Chapter 2 Conducted Emission Test	
Test Condition and Setup	9
Conducted Test Placement	10
Chapter 3 Radiated Emission Test	
Test Condition and Setup	11
Radiated Test Placement	12
Chapter 4 Electrostatic Discharges Immunity Test	13
EN 61000-4-2 Photo of Test Set-Up	14
Chapter 5 Radio Frequency Immunity Test (RS test)	15
EN 61000-4-3 Photo of Test Set-Up	16
Chapter 6 Electrical Fast Transient/Burst Test (EFT test)	17
EN 61000-4-4 Photo of Test Set-Up	18
Chapter 7 Surge Immunity Test	19
EN 61000-4-5 Photo of Test Set-Up	20
Chapter 8 Continuous Wave Voltage Immunity Test	21
EN 61000-4-6 Photo of Test Set-Up	22
Chapter 9 Power Frequency Magnetic Field Immunity Test	23
EN 61000-4-8 Photo of Test Set-Up	24
Chapter 10 Voltage DIP / Interruption Immunity Test	25
EN 61000-4-11 Photo of Test Set-Up	26
Chapter 11 Harmonics Test	27
Chapter 12 Voltage Fluctuation and Flicker Test	28
Appendix A :	
Conducted test result	29
Appendix B :	
Radiated test result	31
Appendix C :	
Photographs of EUT	32

Chapter 0 Emission and Susceptibility Standards

Emission Standards

Emission Standard	European Standard	International Standard
(X)	EN 50081-1/1992	
()	EN 50081-1/8.93	
()	EN 55014/4.93	CISPR 14: 1993
()	EN 55015/12.93	CISPR 15: 1992
()	EN 55011/91	CISPR 11: 1990
(X)	EN 55022/1998	CISPR 22: 1997
(X)	EN61000-3-2:1995+A1:1998 +A2:1998	IEC 61000-3-2: 1995 /A1:1997/A2:1998
(X)	EN 61000-3-3/1995	IEC 61000-3-3: 1994

Susceptibility Standards

Susceptibility Standard	European Standard	International Standard
()	EN 50082-1/1997	
(X)	EN 55024/1998	
()	EN 50082-2/1994	
()		IEC 801-2/1984
()		IEC 801-3/1984
()		IEC 801-4/1988
()		IEC 804-5
(X)	EN 61000-4-2:1995	IEC 61000-4-2:1995
(X)	EN 61000-4-3:1996	IEC 61000-4-3:1995(mod)
(X)	EN 61000-4-4:1995	IEC 61000-4-4:1995
(X)	EN 61000-4-5:1995	IEC 61000-4-5:1995
(X)	EN 61000-4-6:1996	IEC 61000-4-6:1996
(X)	EN 61000-4-8:1993	IEC 61000-4-8:1993
(X)	EN 61000-4-11:1994	IEC 61000-4-11:1994
()	EN 55014-2:1993	CISPR/F (Sec) 159
()		

Chapter 1 Introduction

Description of EUT:

The EUT is a data transmission / receiver facility. It is designed to install in the PC or compatible computer and makes your data equipment available to transmit / receive data via the EUT. During testing the EUT was operated at Tx or Rx mode for each emission measured. This was done in order to insure that maximum emission levels were attained.

Test method:

Pretest was found that the emission of operating mode is worse than standby mode. So, The final test is made at the operating mode.

The power adaptors as below for used:

Trade	Model No.	Input Rating	Output Rating
DVE	DSA-0151A-05 A (U)	200-240Vac 50-60Hz 0.4A	5.0Vdc 2.4A
LEI	MU15-050240-C5	100-240Vac 50/60Hz 0.5A	5.0Vdc 2.4A
LEI	MU15-050240-A1	100-240Vac 50/60Hz 0.5A	5.0Vdc 2.4A

During the measurement, these adaptors as above were verified, the test modes as below:

1. 10 x 10Mbps
2. 100 x 100Mbps
3. 100 x 1000Mbps

The conduction of power line test was found out the testing mode: “**10 x 100Mbps used LEI MU15-050240-A1 adaptor**“ was the worst case. The conduction of data line test was found out the testing mode: “**100 x 100Mbps used LEI MU15-050240-A1 adaptor**“ was the worst case.

The radiation pretest was found out the testing mode: “**1000 x 1000Mbps used DVE DSA-0151A-05 A (U) adaptor**“ was the worst case. We only recorded the worst case in this report.

During testing, the EUT was operated at “transmitting” and “receiving” mode simultaneously.

The test placement as the photographs showed is the worst case emission placed. (If the emission is close to the ambient, the resolution BW and view resolution will be reduced and the data will be recorded by detection of maximum hold peak mode.)

The testing configuration of test setup is showing in the next page.

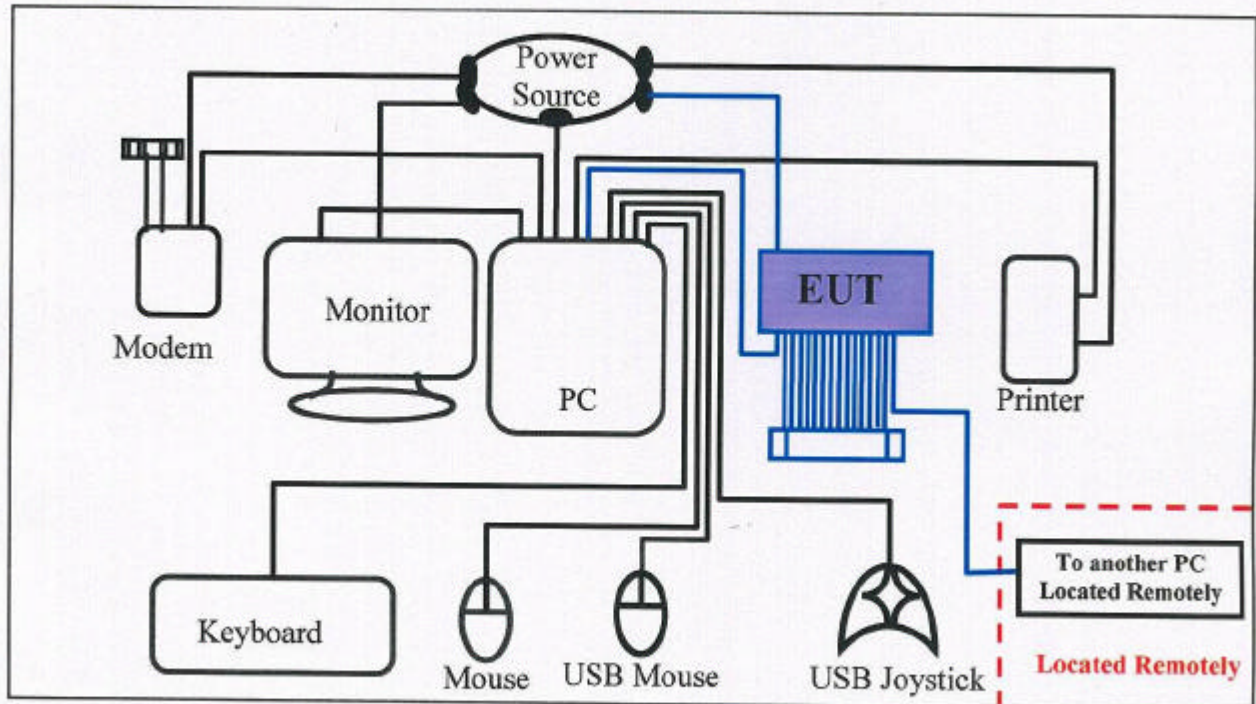
Configuration of test setup**Connections:****PC:**

- *Serial Port --- via a 110cm shielded RS-232 cable to modem.
- *Monitor Port --- a monitor with 1.5m length data cable.
- *Keyboard port --- a keyboard with 1.50m length data cable.
- *Mouse port --- a mouse with 1.50m length data cable.
- *USB port A --- a USB joystick with 1.5m long, shielded, no ferrite bead data cable.
- *USB port B --- a USB mouse with 1.8m long, shielded, no ferrite bead data cable.
- *Printer port --- a printer with 1.80m length data cable.

EUT:

- *UTP port 1 --- via a 3 m length RJ-45 cable to the RJ-45 jack of the LAN card that installed in nearby PC.
- *UTP port 2~7 --- connect with a 2m length RJ-45 cable that terminated with 200ohm.
- *UTP port 8 --- via a 10 m length RJ-45 cable to another PC Located Remotely.
- *Power port --- via a 1.80m length power cable with a power adaptor to the power source.
- *Power adaptor --- Trade: DVE; Model: DSA-0151A-05 A (U); I/P: 200-240Vac 50-60Hz 0.4A; O/P: 5.0Vdc 2.4A
- *Power adaptor --- Trade: LEI; Model: MU15-050240-C5; I/P: 100-240Vac 50/60Hz 0.5A; O/P: 5.0Vdc 2.4A
- *Power adaptor --- Trade: LEI; Model: MU15-050240-A1; I/P: 100-240Vac 50/60Hz 0.5A; O/P: 5.0Vdc 2.4A

List of support equipment

Conducted (Radiated) test:

PC : **HP Pavilion t123d**
Model No. : DD281A-AB0
Serial No. : TW31720157
FCC ID : Doc Approved
Power type : AC 100 -127 4.0A, 200-240 2.0A, 50 ~ 60Hz
Power cord : Non-shielded, 2.33m long, Plastic, No ferrite core

Monitor : **HP pavilion mx70**
Model No. : P1283A
Serial No. : THTBR00257
FCC ID : DOC Approved
Power type : 100 ~ 240V AC 15A 50/60Hz
Power cord : Shielded, 1.83m long, No ferrite core
Data cable : Shielded, 1.46m (1.80m) long, with two ferrite cores (no ferrite core)

Keyboard : **HP**
Model No. : 5219
Serial No. : BN31206351
FCC ID : E5XKB5209
Power type : By PC
Data cable : Shielded, 1.60m long

Mouse : **HP**
Model No. : MO42KOA
Serial No. : 0306044011
FCC ID : DOC Approved
Power type : By PC
Power cord : Non-shielded, 1.88m long, No ferrite core

USB Mouse : **Logitech Wheel Mouse**
Model No. : M-BJ-58
Serial No. : LN20901985
FCC ID : Doc Approved
Power type : By PC
Power cord : Non-shielded, 1.88m long, No ferrite core

Modem : **ACEEX**
Model No. : XDM-9624
FCC ID : IFAXDM-9624
Power type : 220VAC, 50Hz / 9VAC, 1A
Power cord : Non-shielded, 1.9m long, No ferrite cord
Data cable : RS232, Shielded, 1.2m long, No ferrite core
RJ11C x 2, 7' long non-shielded, No ferrite core

Printer : **HP**
Model No. : C2642A
Serial No. : SG69A196GV
FCC ID : B94C2642X
Power type : 220 VAC, 50Hz
Power cord : Non-shielded, 2m long, no ferrite core
Data cable : Shielded, 1.84m (1.7m) long, no ferrite core

USB Joystick : **Rockfire**
Model No. : QF-337uv
Serial No. : 10600545
FCC ID : CE Approval
Power type : Powered by PC
Power cable : Shielded, 1.8m long, No ferrite bead data cable

PC : **HP Vectra VE**
Model No. : D6970A
Serial No. : SG53000707
FCC ID : Doc Approved
Power type : 100 ~ 230VAC / 50 ~ 60Hz, 5A, Switching
Power cord : Non-shielded, 2.30m long, Plastic, No ferrite core

Chapter 2 Conducted Emission Test

Test condition and setup:

(1) Mains:

All the equipment is placed and setup according to the EN 55022. The EUT is assembled on a wooden table that is 80 cm high, is placed 40 cm from the back-wall that is a vertical conducting plane. One LISN is for EUT, the other LISN is for support equipment. They are all placed on the conductive ground. The EUT's LISN connect a line switch box for selecting L1 or L2, then connect to a preamplifier and spectrum for pretest.

The spectrum measured from 150KHz to 30MHz. Conducted emission levels are detected at max. peak mode. But if the max. peak mode failed or over average limit, it will be measured by QP and average detection mode using the Receiver.

While testing, there is the worst-emission plot printed at peak detection mode, and there are more than 6 highest emissions relative to limit recorded. The plot is kept as the original data, not included in test report.

(2) Telecommunication ports:

The EUT is placed as mains disturbance test. The communication line connected to the ISN and then the measuring receiver connected to the ISN to measured the level of voltage disturbance.

List of test Instrument :

Instrument Name	Model No.	Brand	Serial No.	Calibration Date	
				Last time	Next time
Receiver	SCR3102	SCHAFFNER	012	04/22/03	04/21/04
LISN (EUT)	3825/2	EMCO	9411-2284	07/21/03	07/20/04
LISN (Support E.)	3825/2	EMCO	9210-2007	09/03/03	09/02/04
Preamplifier	CB-001	TRC	98-02	05/29/03	05/28/04
Line switch box	CB-01	TRC	98-04	05/29/03	05/28/04
FTB-1-6 Attenuator	15542	mini-circuits	9620 03	05/29/03	05/28/04
20dB Attenuator	CAT-20	mini-circuits	9620 13	05/29/03	05/28/04
Coixal Cable	BNC3200B-0058	Jyebao	CL-05	05/29/03	05/28/04
Coixal Cable	BNC31VB-0316	Jyebao	IF-01ca0069-036	05/29/03	05/28/04
50ohm terminator	370BNM	NARDA	PWR5W	07/21/03	07/20/04
50ohm terminator	370BNM	NARDA	PWR5W	07/21/03	07/20/04
50ohm terminator	370BNM	NARDA	PWR5W	09/03/03	09/02/04
50ohm terminator	370BNM	NARDA	PWR5W	09/03/03	09/02/04
ISN	ISN T400	SCHAFFNER	16596	04/16/03	04/16/04

The level of confidence of 95% , the uncertainty of measurement of conducted emission is +3.1/-4.84 dB .

Test Result : Pass (Appendix A)

Conducted Test Placement: (Photographs)(Power Line)

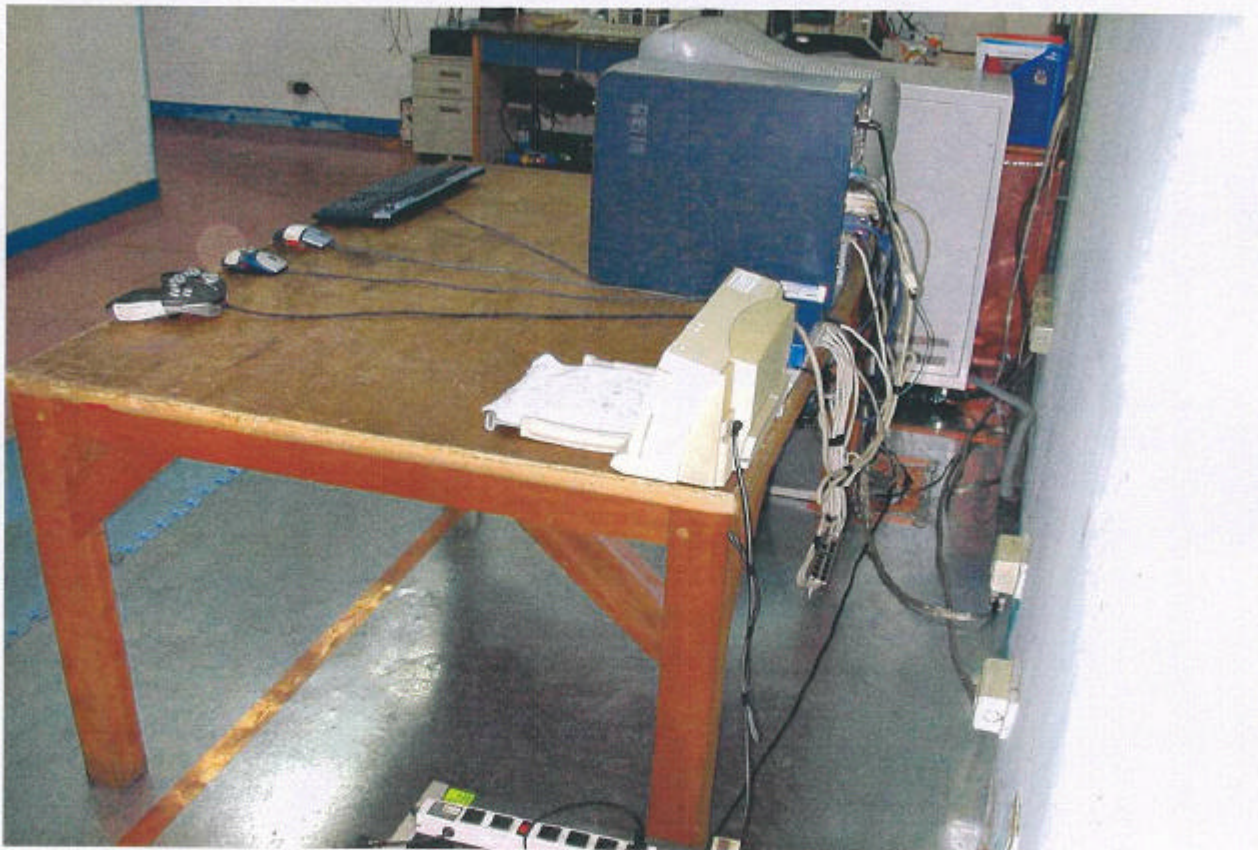

Conducted Test Placement: (Photographs)(Data Line)

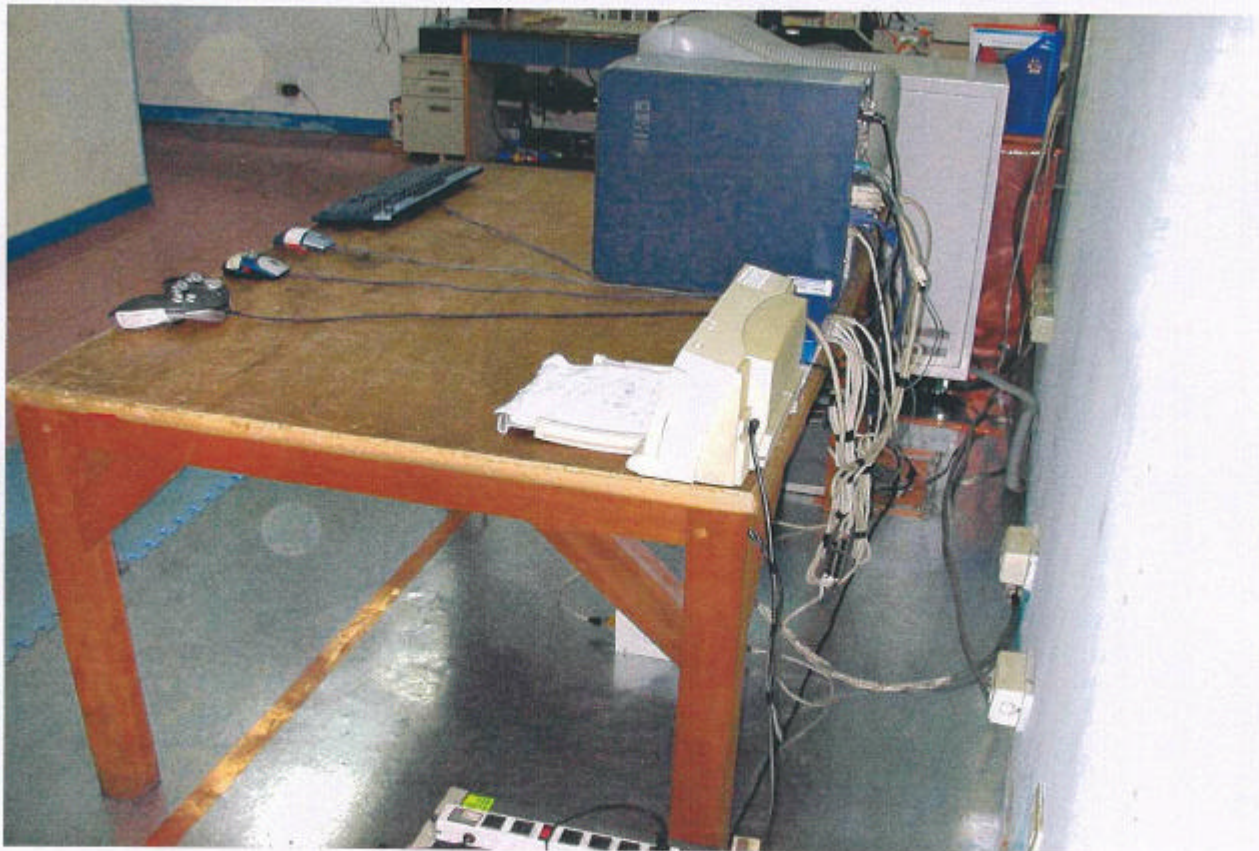
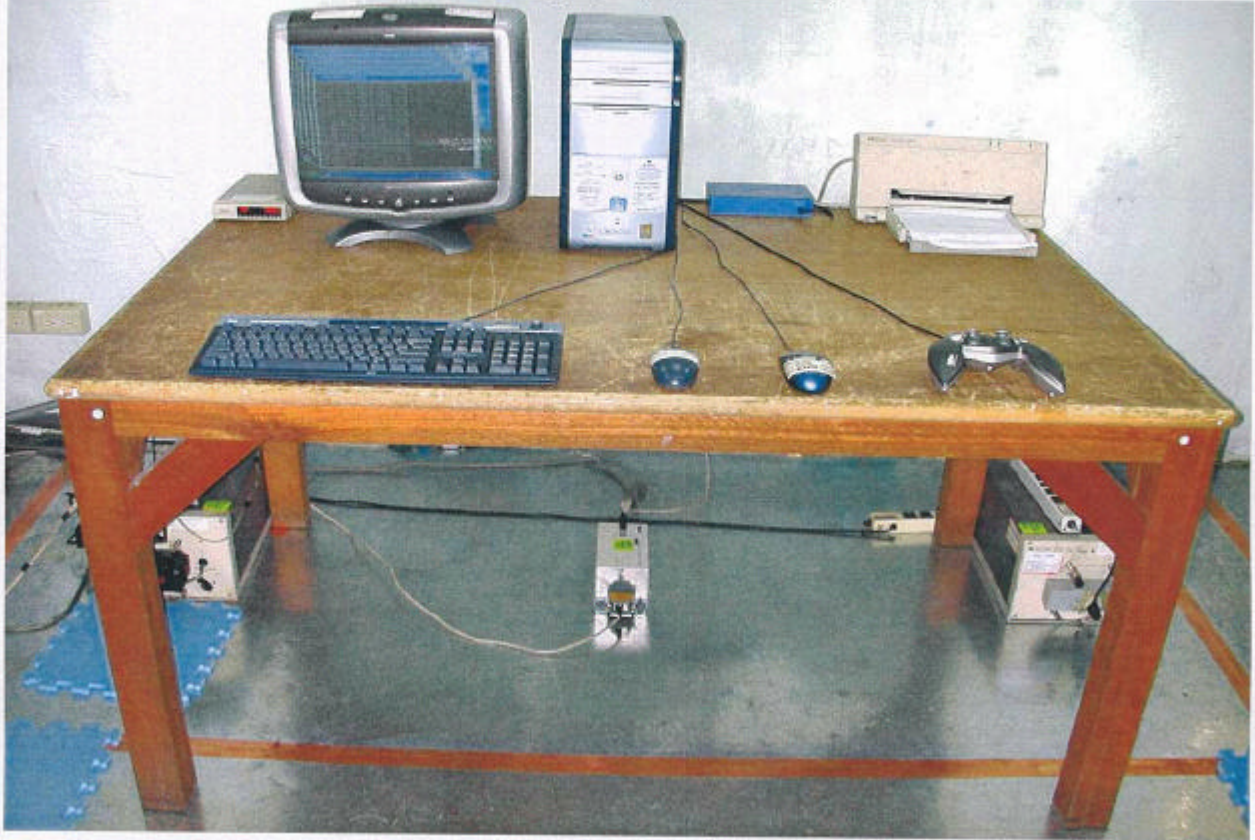

Chapter 3 Radiated emission test

Test condition and setup :

Pretest: Prior to the final test (OATS test), the EUT is placed in a shielded enclosure, and scan from 30MHz to 1GHz. This is done to ensure the radiation is exactly emitted from the EUT.

Final test : Final radiation measurements is made on a **10 – meter**, open-field test site. The EUT is placed on a nonconductive table, which is 0.8m height, the top surface is 1.0 x 1.5 meter. The placement is according to EN 55022.

The M. E. whole range Antenna is used to measure frequency from 30 MHz to 1GHz. The final test is used the Receiver.

Measure more than six top marked frequencies generated form pretest by computer step by step at each frequency. The EUT is rotated 360 degrees, and antenna is raised and lowered from 1 to 4 meters to find the maximum emission levels. The antenna is used with both horizontal and vertical polarization.

Appropriated preamplifier that is made by TRC is used for improving sensitivity and precaution is taken to avoid overloading. The spectrum analyzer’s 6dB bandwidth is set to 120 K Hz, and the EUT is measured at quasi-peak mode.

If the emission is close to the frequency band of ambient, the tester will recheck the data and the corrected data will be written in the test data sheet. If the emission is just within the ambient, the data from shielded room will be taken as the final data.

List of test Instrument :

Instrument Name	Model No.	Brand	Serial No.	Calibration Date	
				Last time	Next time
Receiver	SCR3102	SCHAFFNER	012	04/22/03	04/21/04
Control Box	TWR95-4	TRC	C9001-2	N/A	N/A
Antenna	CBL6141A	SCHAFFNER	4206	05/27/03	05/26/04
Open test side (Antenna, Amplify, cable calibrated together)				05/29/03	05/28/04
Pre-amplifier	TRC-CB-2	TRC	CB-002	05/29/03	05/28/04
Coixal Cable(20meter)	RG-214/U	Jyebao	CL-002	05/29/03	05/28/04
Coixal Cable(50cm)	BNC31VB-0316	Jyebao	CL-002	05/29/03	05/28/04
Coixal Cable(20cm)	BNC31VB-0318	Jyebao	CL-007	05/29/03	05/28/04
Coixal Cable(55cm)	BNC31VB-0316	Jyebao	CL-006	05/29/03	05/28/04
Coixal Cable(55cm)	BNC31VB-0316	Jyebao	CL-005	05/29/03	05/28/04

The level of confidence of 95%, the uncertainty of measurement of radiated emission is +2.85/-2.77 dB.

Test Result : Pass (Appendix B)

Radiated Test Placement: (Photographs)



Chapter 4 Electrostatic Discharges Immunity Test

Test information:

Test setup: According to EN 61000-4-2

Test Voltage: 4KV contact discharge
 8KV air discharge

Indirect Discharges: HCP
 VCP

Polarity: positive negative

Test mode: Ref. Test method of Chapter 1

Test points: Each Port of EUT

Test instruments:

Name	Model Number	Serial Number	Selected
NoiseKen Electrostatic Discharge Simulator	ESS-100L(A)	2100C03605	X
NoiseKen Electrostatic Discharge Gun	TC-815P	2100C03566	X

Comment:

Performance Criteria A B C

Test Result : Pass

EN 61000-4-2 PHOTO OF TEST SET-UP



Chapter 5 Radio Frequency Immunity Test (RS)

Test information:

Test setup: According to EN 61000-4-3

Test Frequency: 80 ~ 1000 MHz
 27 ~ 500 MHz Without Modulation

Modulation: FM %
 80% AM Modulation with 1KHz
 900 KHz ± 5 KHz with PM 200 Hz and 100% depth

Step size: ≤ 1% step size

Sweep time: 2.5 Second

Field strength: 1V/m 3V/m 10V/m

Test mode: Ref. Test method of Chapter 1

Test instruments:

Name	Model Number	Serial Number	Selected
Shielding Room	AC5-001	N / A	X
DC Power Supply	GPR-3520H	7090069	X
Signal Generator	900	287104	X
Amplifier	AC5-002	N / A	X
Power Meter	1219-D-007	157	X
Spectrum Analyzer	8594EM	3710A00198	X
Preamplifier	AC3-002	N / A	X

Comment:

Performance Criteria A B C

Test Result : Pass

EN 61000-4-3 PHOTO OF TEST SET-UP

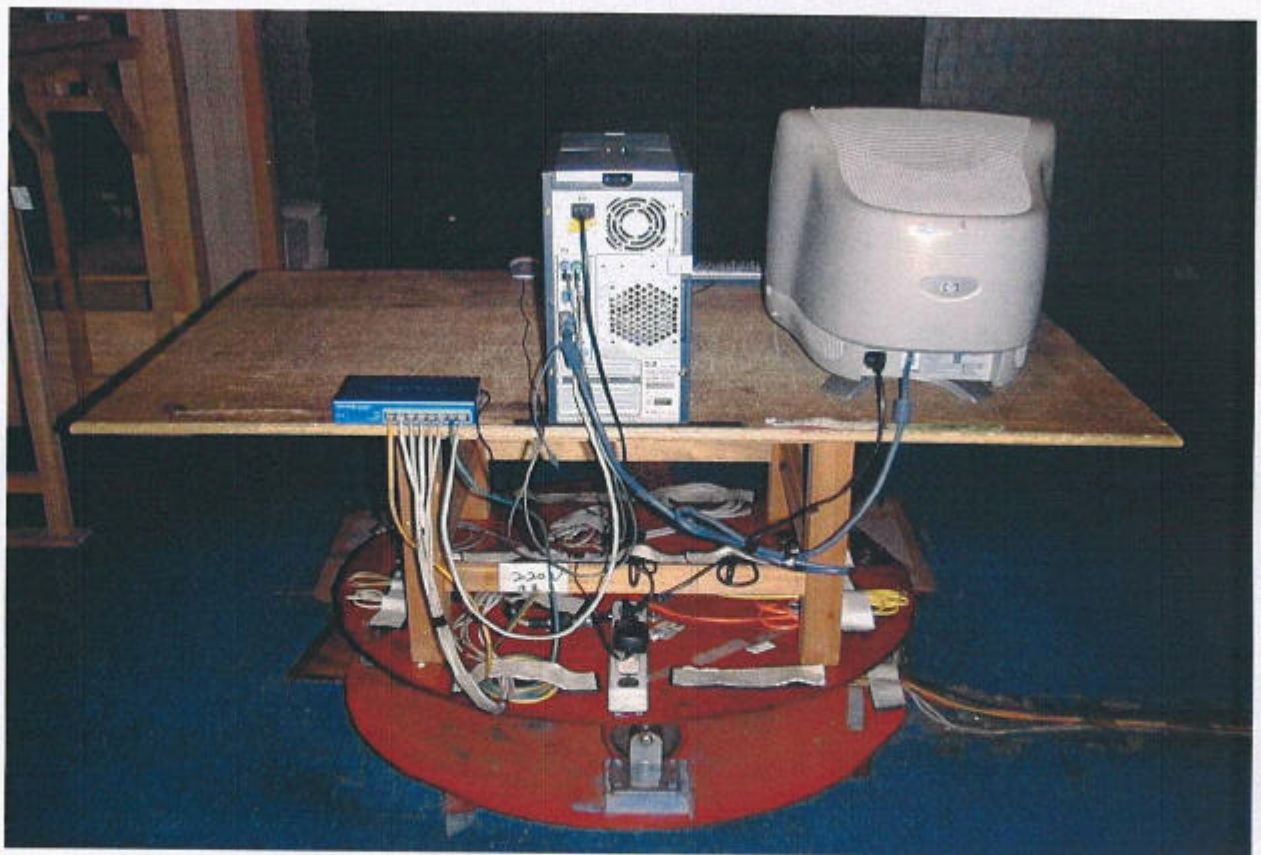
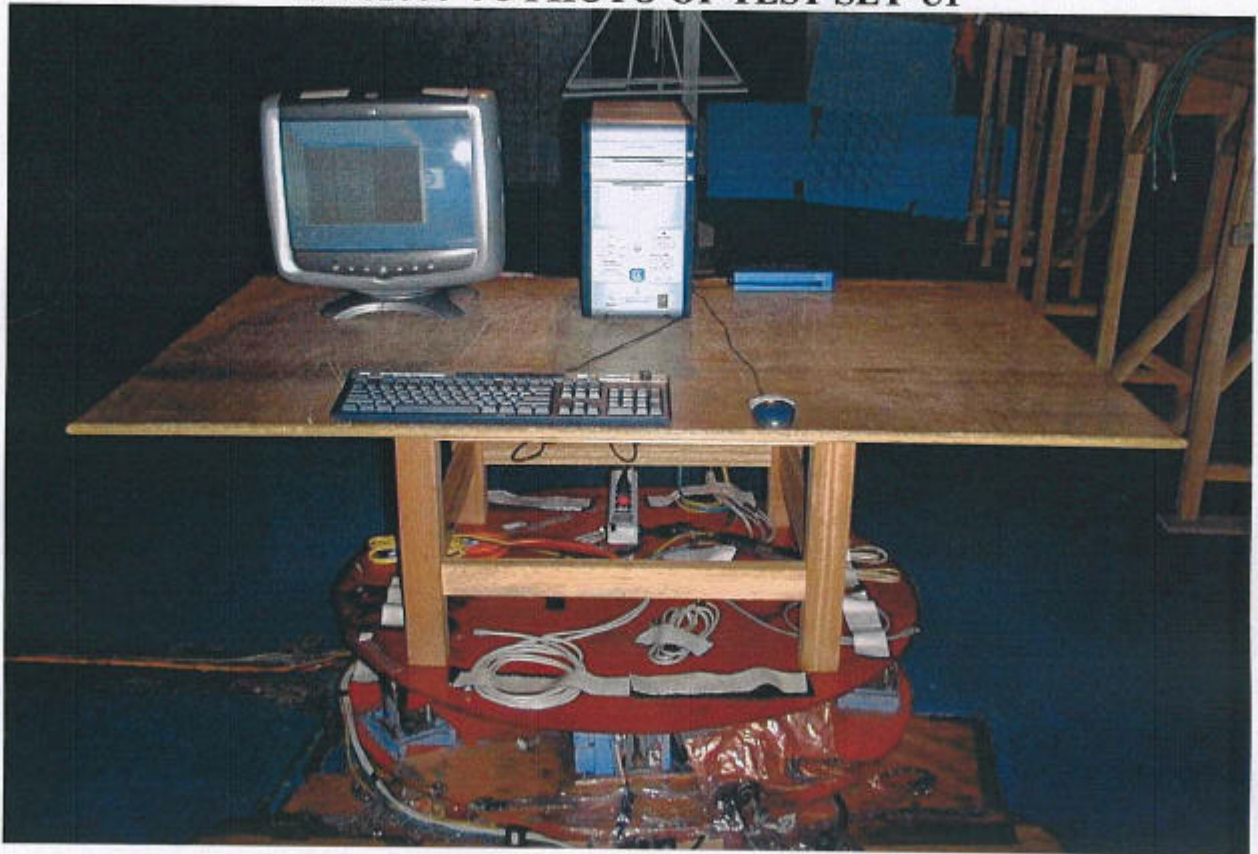

Chapter 6 Electric Fast Transient/Burst Requirements Test

Test information:

Test setup: According to EN 61000-4-4

Test Voltage: DC Power line () 0.5 KV, 5 KH
 AC Power line (X) 1 KV, 5 KHz
 Signal & Control line (X) 0.5 KV, 5 KHz
 () 1 KV, 5 KHz

Polarity: (X) Positive (X) Negative

Test Duration: () 1 minute (X) 3 minutes

Connected lines: () Power line shielded
 (X) Power line non-shielded
 (X) Signal & Control line non-shielded
 () Signal & Control line shielded

Test mode: Ref. Test method of Chapter 1.

Test instruments:

Name	Model Number	Serial Number	Selected
BEST EMC Test Instrument	BEST EMC V2.3 (-8, -9)	199918-006SC	X
Induction Coil	INA 701 BEST	199922-001SC	X

Comment:

Performance Criteria () A (X) B () C

Test Result : Pass

EN 61000-4-4 PHOTO OF TEST SET-UP

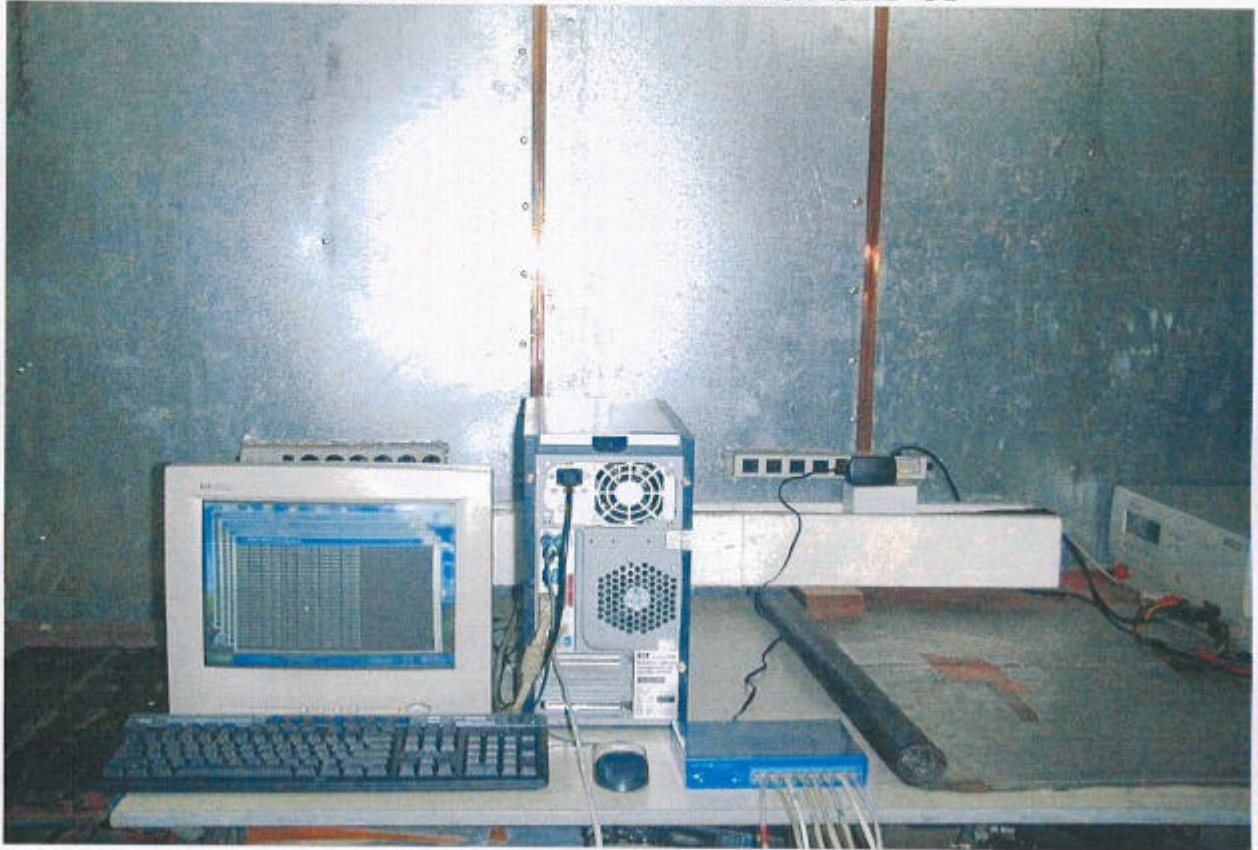

Chapter 7 Surge Immunity Test

Test information:

Test setup: According to EN 61000-4-5

Test Voltage: DC Power line () 0.5 KV
 AC Power line (X) 1 KV, line to line
 (X) 2 KV, line to ground
 Control line () 0.5 KV
 Signal () 1 KV, line to ground

Time : (X) 1.2/50µs (8/20µs)

Connected lines: () Power line shielded (X) Power line non-shielded
 () Signal & Control line non-shielded () Signal & Control line shielded

Test mode: Ref. Test method of Chapter 1.

Test instrument:

Name	Model Number	Serial Number	Selected
BEST EMC Test Instrument	BEST EMC V2.3 (-8, -9)	199918-006SC	X
Induction Coil	INA 701 BEST	199922-001SC	X
KeyTek Pulsed-EMI Test System	E103, E501B, E502B, E503, E505A, E4552A	0008260 ~0008264, 0008254	

Comment:

Performance Criteria: () A (X) B () C

Test Result : Pass

EN 61000-4-5 PHOTO OF TEST SET-UP



Chapter 8 Continuous Wave Voltage Immunity Test

Test information:

Test setup: According to EN 61000-4-6

Test Frequency: 0.15 ~ 80MHz

Modulation: FM %
 80% AM Modulation with 1KHz
 900 MHz ± 5 MHz with PM 200 Hz and 50% duty cycle

Step size: ≤ 1% step size

Field strength: 1V 3V 10V

Test mode: Ref. Test method of Chapter 1

Test instruments:

Name	Model Number	Serial Number	Selected
SCHAFFNER RF-SYNTHESIZER IAMP2IFIER	NSG 2070-1	1020	X
SCHAFFNER CDN	M325	13773	X
SCHAFFNER CDN	M216	15604	
SCHAFFNER CDN	T004	15230	X
SCHAFFNER CDN	S501	15167	
SCHAFFNER FM-Koppelzange	KEMZ 801	14301	

Comment:

Performance Criteria: A B C

Test Result : Pass

EN 61000-4-6 PHOTO OF TEST SET-UP

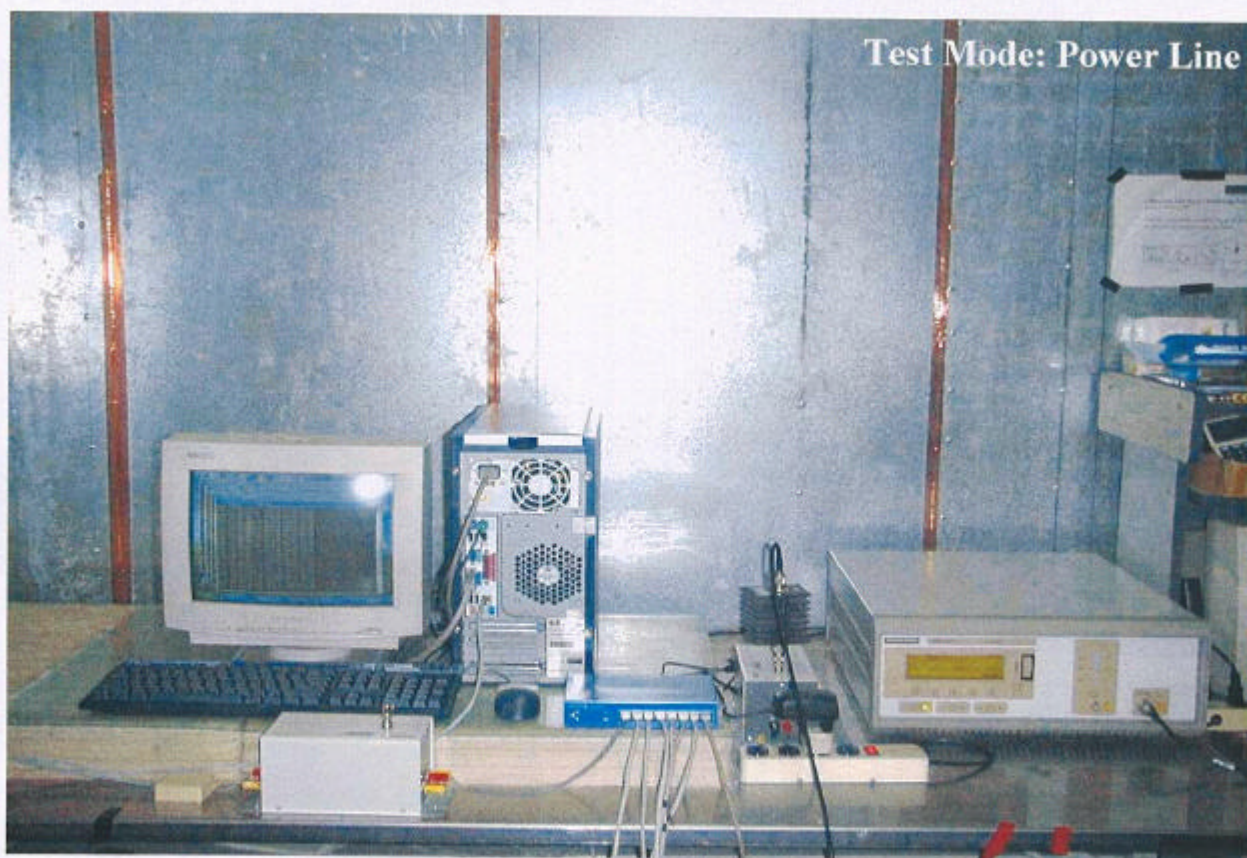
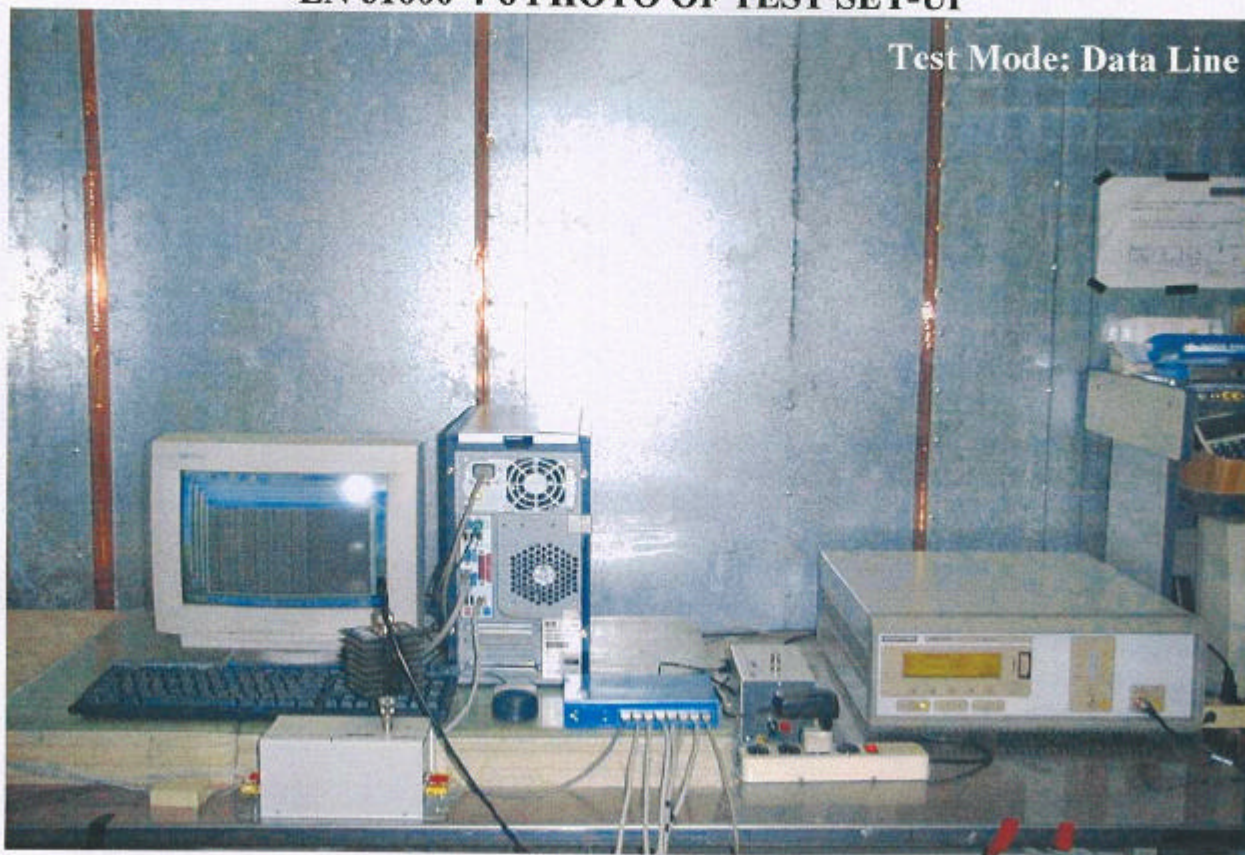

Chapter 9 Power Frequency Magnetic Field Immunity Test

Test information:

Test setup: According to EN 61000-4-8

Test method : (X) Continuous () Short duration

Magnetic Field Strength: (X) 1A/m

Frequency: 50Hz

polarization: (X) X polarization (X) Y polarization (X) Z polarization

Test mode: Ref. Test method of Chapter 1

Test Duration: (X) 30 seconds () 1~3 seconds

Connected lines: () Power line shielded (X) Power line non-shielded
 (X) Signal & Control line non-shielded () Signal & Control line shielded

**** Power Frequency Magnetic Field in the horizontal and vertical polarity.****

Test instruments:

Name	Model Number	Serial Number	Selected
BEST EMC Test Instrument	BEST EMC V2.3 (-8, -9)	199918-006SC	X
Induction Coil	INA 701 BEST	199922-001SC	X

Comment:

Performance Criteria: (X) A () B () C

Test Result : Pass

EN 61000-4-8 PHOTO OF TEST SET-UP

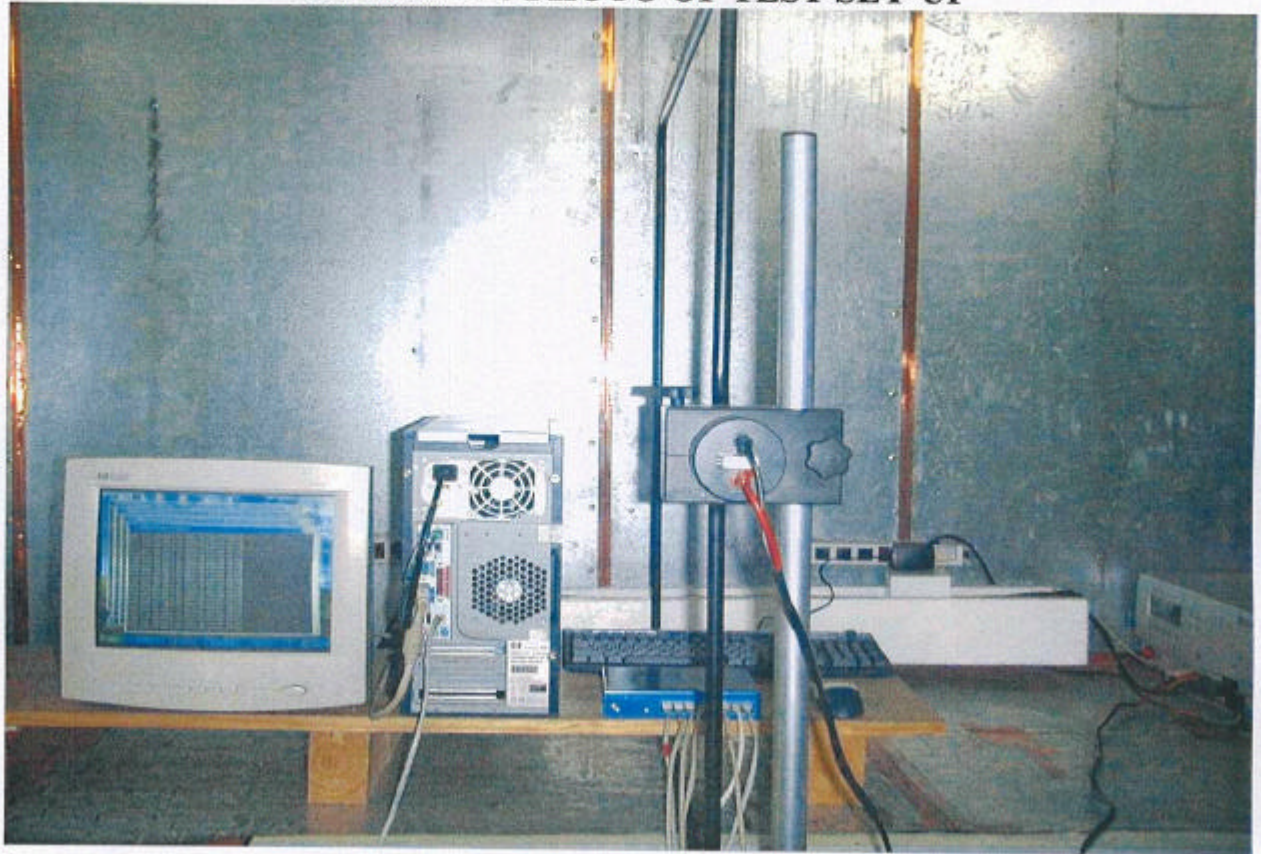

Chapter 10 Voltage DIP / Interruption Test

Test information:

Test setup: According to EN 61000-4-11

Voltage dips / Test specification / Units: (X) > 95%, 0.5period

(X) 30%, 25periods

Voltage interruptions/ Test specification / Units: (X) > 95%, 250periods

Test mode: Ref. Test method of Chapter 1

Test instruments:

Name	Model Number	Serial Number	Selected
BEST EMC Test Instrument	BEST EMC V2.3 (-8, -9)	199918-006SC	X
Induction Coil	INA 701 BEST	199922-001SC	X

Comment:

Performance Criteria:

Dips: (1) >95% →	() A	(X) B	() C
Interruptions : (2) >95% →	() A	() B	(X) C
Dips : (3) 30% →	() A	() B	(X) C

Test Result : Pass

EN 61000-4-11 PHOTO OF TEST SET-UP

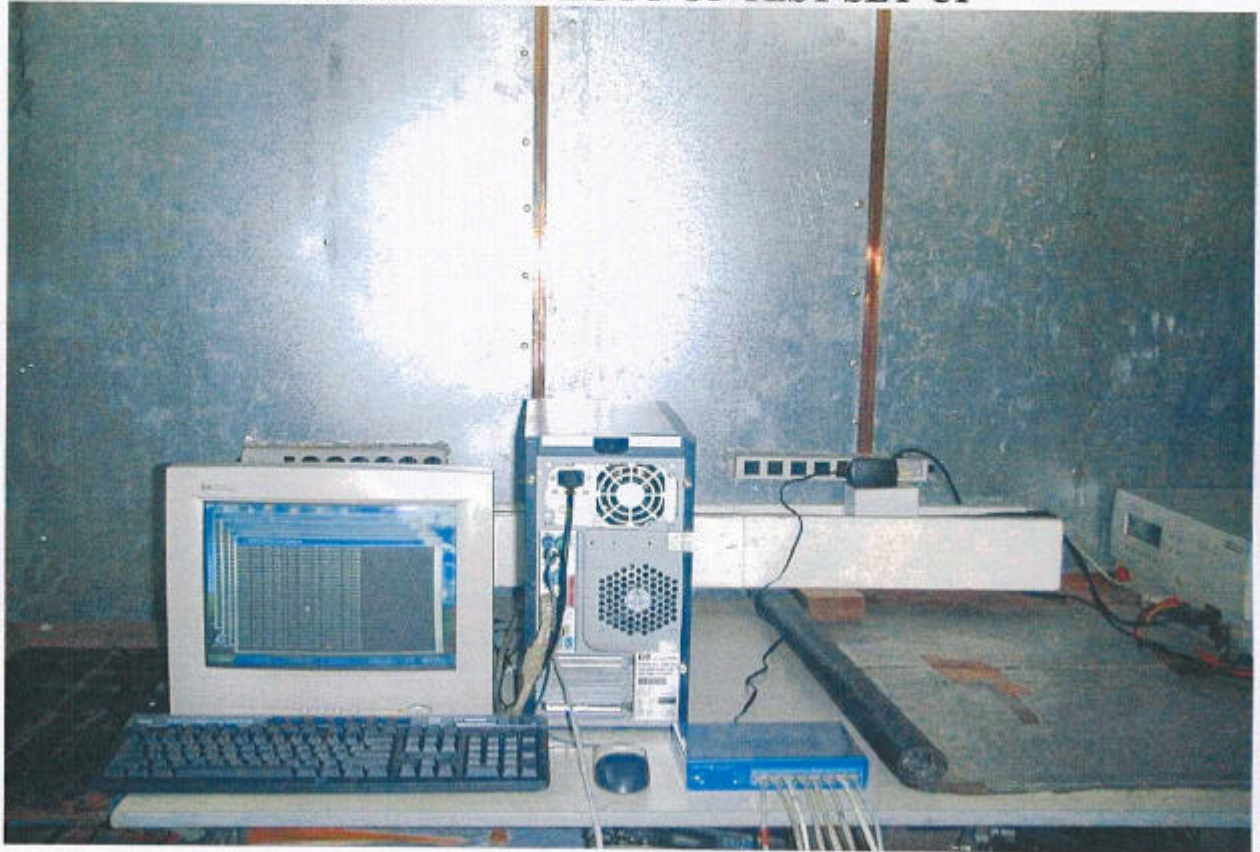

Chapter 11 Harmonics Test

Test information:

Test setup: According to EN 61000-3-2

Test Item: Quasi – stationary & Fluctuating Current Harmonics Test

Test mode: Ref. Test method of Chapter 1

Test instrument:

Name	Model Number	Serial Number	Selected
Harmonic/Flicker Test System	HP 6842A	3531A-00102	X

Test Equipment Settings:	Quasi-stationary Current Harmonics Test	Fluctuating Current Harmonics Test
Line Voltage	230VAC	230VAC
Line Frequency	50Hz	50Hz
Device Class	D	D
Test Limit Overrides	None	None
Total Number of Failures:	None	None
Total Number of Errors:	None	None

Test Result: PASS

Chapter 12 Voltage Fluctuation and Flicker Test

Test information:

Test setup: According to EN 61000-3-3

Test mode: Ref. Test method of Chapter 1

Test instrument:

Name	Model Number	Serial Number	Selected
Harmonic/Flicker Test System	HP 6842A	3531A-00102	X

Test Equipment Settings:	
Line Voltage	230VAC
Line Frequency	50Hz
Test Limit Overrides	None
Total Number of Failures:	Pst: (0), Plt: (0)
	Dc: (0), Dmax (0), Dt (0)
Total Number of Errors:	None

Test Result: PASS

Appendix A

Conducted Emission Test Result:

Test Mode: Power Line 10 x 10Mbps used LEI MU15-050240-A1 adaptor

Testing room : Temperature : 22 ° C Humidity : 68 % RH

Line 1

Frequency (KHz)	READING AMPLITUDE			LIMIT		Margin (dB)
	Peak (dBμV)	Quasi-Peak (dBμV)	Average (dBμV)	Quasi-Peak (dBμV)	Average (dBμV)	
152.00	49.20	***.**	***.**	79.00	66.00	-16.80
161.00	47.77	***.**	***.**	79.00	66.00	-18.23
1041.00	40.43	***.**	***.**	73.00	60.00	-19.57
1299.00	40.65	***.**	***.**	73.00	60.00	-19.35
1357.00	42.47	***.**	***.**	73.00	60.00	-17.53
1419.00	42.39	***.**	***.**	73.00	60.00	-17.61
1497.00	43.79	***.**	***.**	73.00	60.00	-16.21
1555.00	45.18	***.**	***.**	73.00	60.00	-14.82
1623.00	45.70	***.**	***.**	73.00	60.00	-14.30
1680.00	43.03	***.**	***.**	73.00	60.00	-16.97

Line 2

Frequency (KHz)	READING AMPLITUDE			LIMIT		Margin (dB)
	Peak (dBμV)	Quasi-Peak (dBμV)	Average (dBμV)	Quasi-Peak (dBμV)	Average (dBμV)	
152.00	56.74	***.**	***.**	79.00	66.00	-9.26
157.00	54.81	***.**	***.**	79.00	66.00	-11.19
161.00	55.43	***.**	***.**	79.00	66.00	-10.57
168.00	53.98	***.**	***.**	79.00	66.00	-12.02
171.00	52.80	***.**	***.**	79.00	66.00	-13.20
179.00	52.85	***.**	***.**	79.00	66.00	-13.15
183.00	52.26	***.**	***.**	79.00	66.00	-13.74
195.00	52.32	***.**	***.**	79.00	66.00	-13.68
205.00	50.13	***.**	***.**	79.00	66.00	-15.87
219.00	48.12	***.**	***.**	79.00	66.00	-17.88

*The reading amplitudes are all under limit.

Conducted Emission Test Result:

Test Mode: Data Line 100 x 100Mbps used LEI MU15-050240-A1 adaptor

Testing room : Temperature : 22 ° C Humidity : 68 % RH

Line 1

Frequency (KHz)	READING AMPLITUDE			LIMIT		Margin (dB)
	Peak (dBµV)	Quasi-Peak (dBµV)	Average (dBµV)	Quasi-Peak (dBµV)	Average (dBµV)	
851.00	58.83	***.**	***.**	87.00	74.00	-15.17
910.00	65.49	54.19	26.39	87.00	74.00	-32.81
941.00	65.48	54.85	25.56	87.00	74.00	-32.15
1009.00	68.82	59.05	27.95	87.00	74.00	-27.95
1055.00	68.14	58.70	26.78	87.00	74.00	-28.30
1120.00	63.53	54.62	18.80	87.00	74.00	-32.38
16150.00	53.51	***.**	***.**	87.00	74.00	-20.49
18210.00	53.53	***.**	***.**	87.00	74.00	-20.47
19750.00	52.45	***.**	***.**	87.00	74.00	-21.55
23200.00	54.62	***.**	***.**	87.00	74.00	-19.38

Line 2

Frequency (KHz)	READING AMPLITUDE			LIMIT		Margin (dB)
	Peak (dBµV)	Quasi-Peak (dBµV)	Average (dBµV)	Quasi-Peak (dBµV)	Average (dBµV)	
839.00	54.82	***.**	***.**	87.00	74.00	-19.18
862.00	59.71	***.**	***.**	87.00	74.00	-14.29
916.00	65.90	53.93	24.53	87.00	74.00	-33.07
960.00	65.64	57.40	27.22	87.00	74.00	-29.60
997.00	68.44	59.03	28.18	87.00	74.00	-27.97
1027.00	68.39	59.04	28.32	87.00	74.00	-27.96
1055.00	68.09	59.13	28.79	87.00	74.00	-27.87
16150.00	54.18	***.**	***.**	87.00	74.00	-19.82
17700.00	52.81	***.**	***.**	87.00	74.00	-21.19
23200.00	52.53	***.**	***.**	87.00	74.00	-21.47

*The reading amplitudes are all under limit.

Appendix B

Radiated Emission Test Result:

Test mode: 1000 x 1000Mbps used DVE DSA-0151A-05 A (U) adaptor

Test Conditions:

Testing site : Temperature : 21° C Humidity : 76 % RH

Frequency	Reading Amplitude	Ant. Height	Table	Correction Factors	Corrected Amplitude	Class A Limit	Margin
MHz	dBμV/m	m	degree	dB	dBμV/m	dBμV/m	dB

(Horizontal)

250.0023	40.98	3.97	89	-1.80	39.18	47.00	-7.82
355.5583	37.04	2.50	208	2.02	39.06	47.00	-7.94
375.0028	41.20	2.50	105	3.15	44.35	47.00	-2.65
625.0043	34.45	3.97	73	10.40	44.85	47.00	-2.15
750.0050	30.25	3.97	65	14.30	44.55	47.00	-2.45
875.0057	27.18	1.00	199	15.65	42.83	47.00	-4.17

(Vertical)

74.7803	43.18	2.50	262	-10.21	32.97	40.00	-7.03
250.0018	40.54	1.01	104	-1.80	38.74	47.00	-8.26
355.5578	36.36	1.01	144	2.02	38.38	47.00	-8.62
375.0023	40.14	10.1	136	3.15	43.29	47.00	-3.71
625.0040	30.27	2.50	215	10.40	40.67	47.00	-6.33
875.0062	26.90	2.50	159	15.65	42.55	47.00	-4.45

Note:

1. Margin = Amplitude - limit, *if margin is minus means under limit.*
2. Corrected Amplitude = Reading Amplitude + Correction Factors
3. Correction factor = Antenna factor + (Cable Loss - Amplitude gain)
(For example : 30MHz correction factor = 15.5 + (-15.26) = 0.24 dB/m)

Appendix C
Photographs of EUT

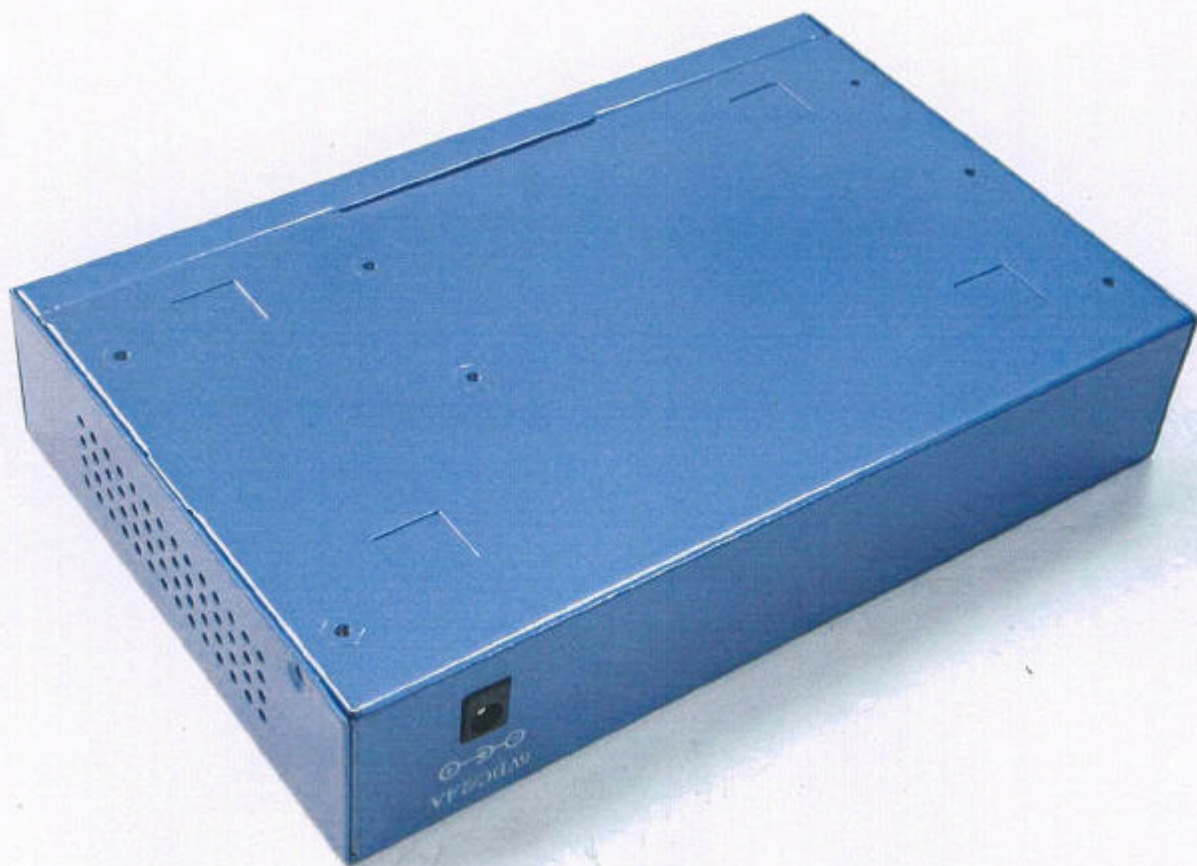

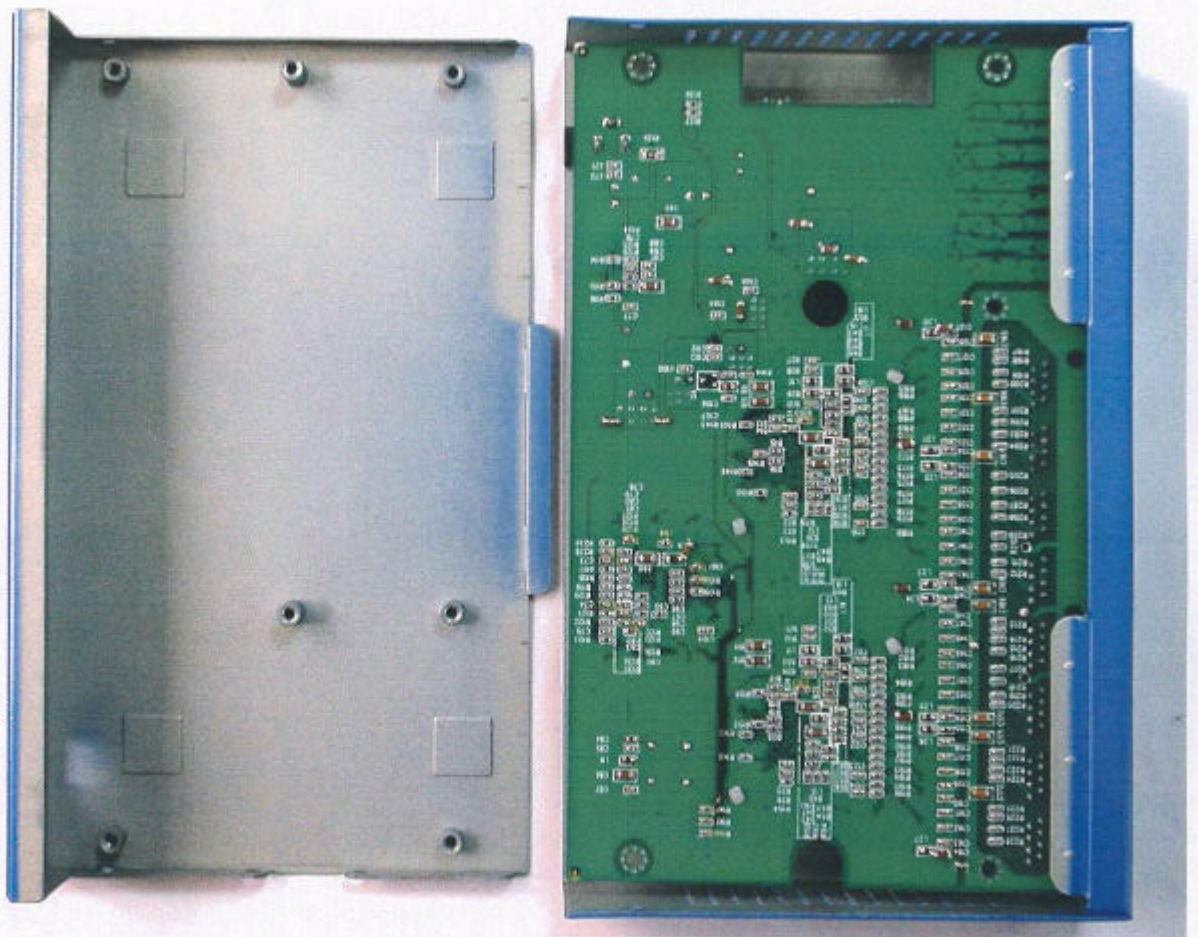
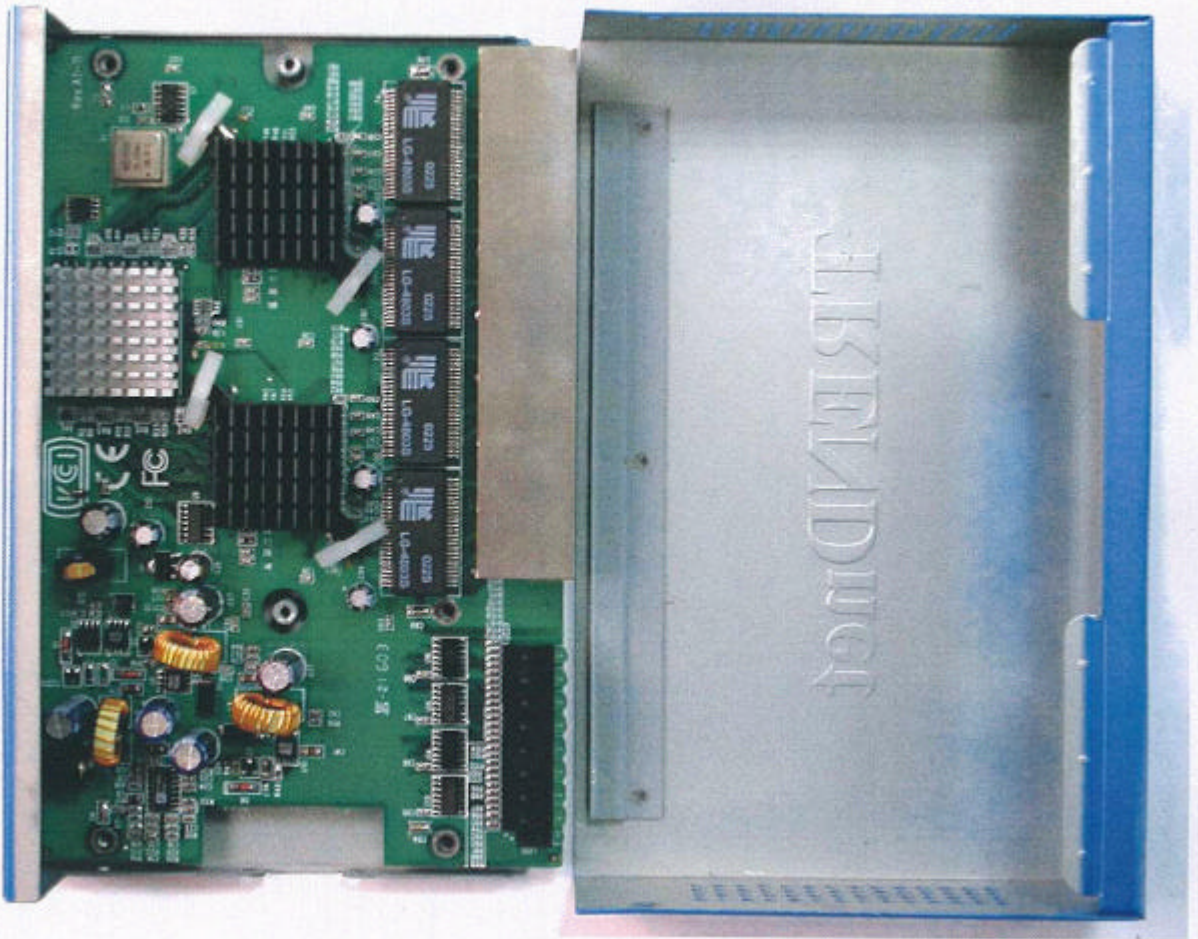

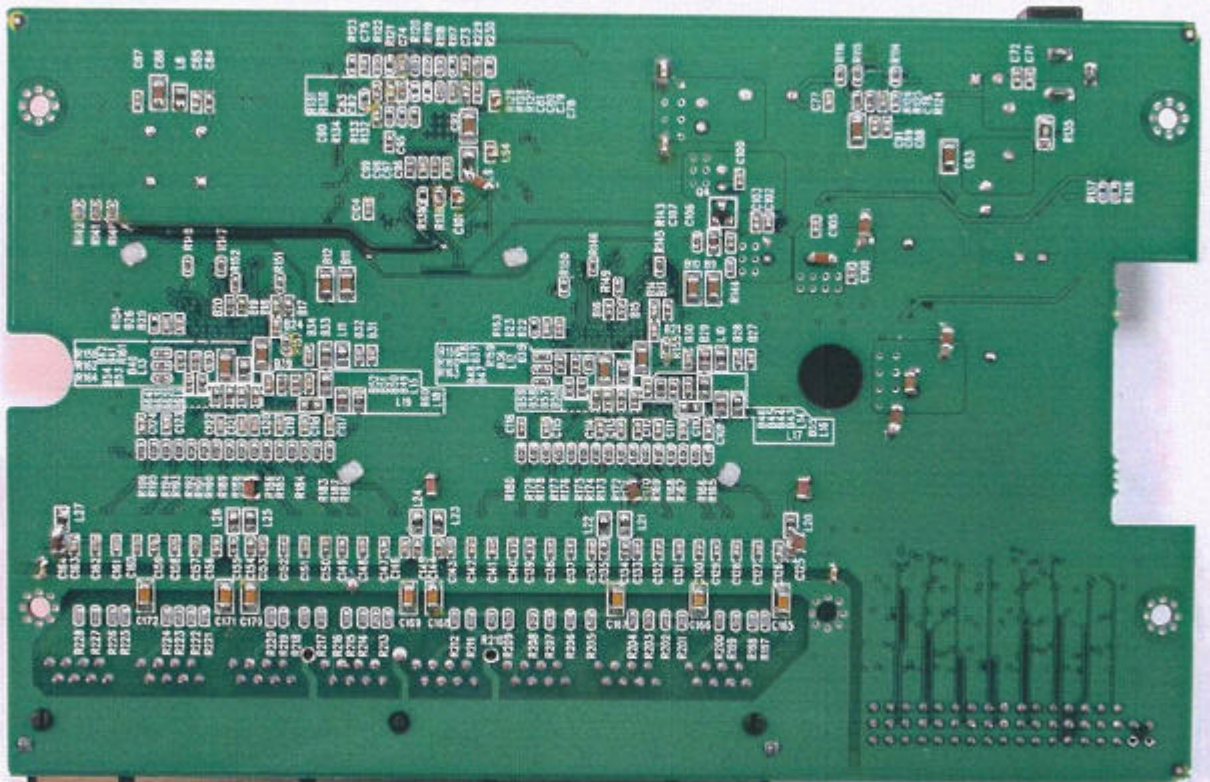
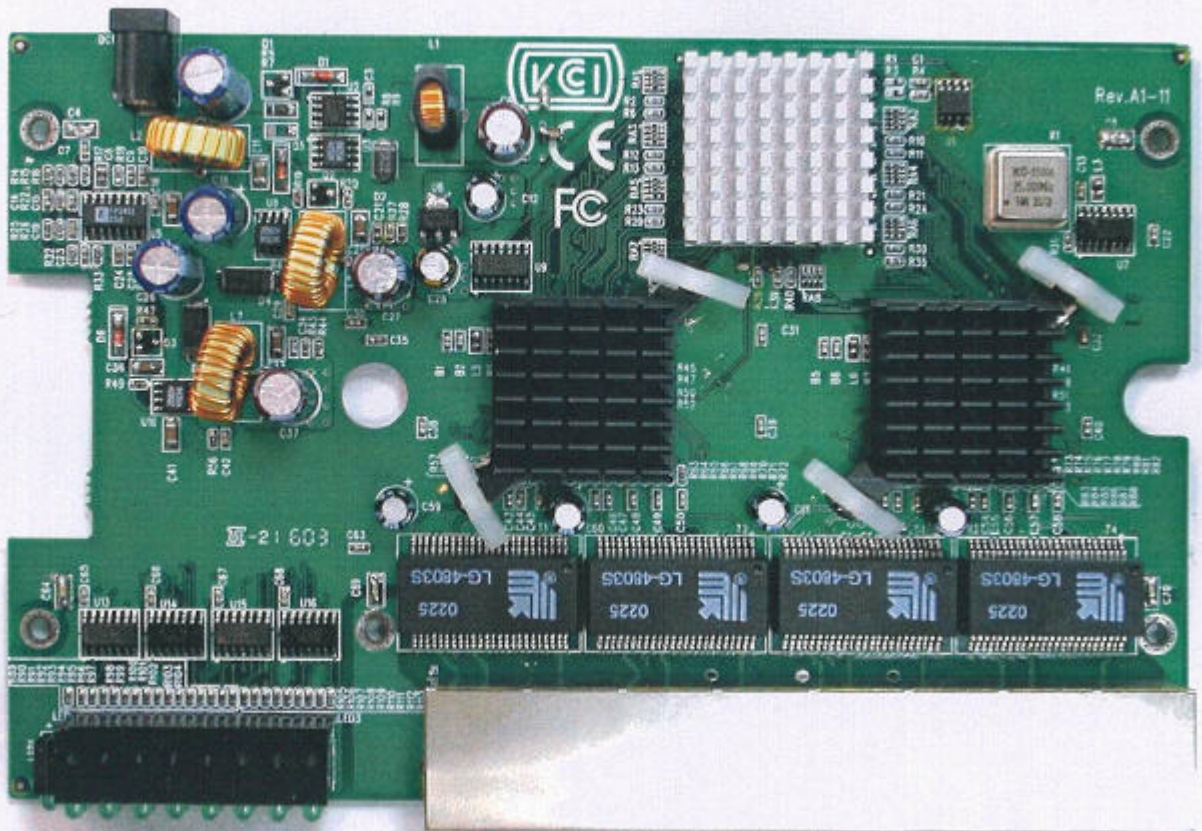



DVE[®]

MODEL: DSA-0151A-05 A (U)
INPUT: 200-240V ~50-60Hz 0.4A
OUTPUT: +5V $\overline{=}$ 2.4A



檢磁 3872A604

YY-1

0101

